

# ADS/NTN

## Atmospheric Precipitation Sampler



*Photo courtesy of University of New Hampshire, Appledore Island, N.H*

## OPERATIONS MANUAL



**N-CON Systems Co. Inc.**  
**P. O. Box 809 – 180 North Street**  
**Crawford, GA 30630**  
**1-800-932-6266 706-743-8110**

**nconsys@n-con.com**  
[www.n-con.com](http://www.n-con.com)

ENGLISH  
Part # 22-120-3

## Table of Contents:

<b>1</b>	<b>SCOPE OF MANUAL.....</b>	<b>1-2</b>
1.1	PURPOSE OF EQUIPMENT .....	1-2
1.2	DETAILED DESCRIPTION OF EQUIPMENT .....	1-2
1.3	TECHNICAL SPECIFICATIONS .....	1-1
<b>2</b>	<b>INSTALLATION SITE SELECTION.....</b>	<b>2-1</b>
2.1	UNPACKING .....	2-2
2.2	STANCHION INSTALLATION.....	2-2
2.3	ATTACH THE SPLASH SHIELD: .....	2-2
2.4	SAMPLER PLACEMENT .....	2-2
2.5	SENSOR INSTALLATION .....	2-2
2.6	POWER CONNECTION AC.....	2-2
2.7	POWER CONNECTION DC AND SOLAR CHARGER .....	2-3
2.8	RECORDER OUTPUT CABLE INSTALLATION .....	2-3
2.9	TEST OPEN SAMPLER .....	2-3
2.10	ALIGN SPLASH SHIELD .....	2-3
2.11	FINAL CHECK OUT.....	2-3
<b>3</b>	<b>OPERATION .....</b>	<b>3-1</b>
3.1	CHANGE SAMPLE CONTAINER .....	3-1
3.2	BULK SAMPLE OPERATION .....	3-1
3.3	ALIGN MOVING COVER .....	3-1
<b>4</b>	<b>DRAWINGS AND ILLUSTRATIONS .....</b>	<b>4-1</b>
4.1	DRAWINGS .....	4-1
4.2	ILLUSTRATIONS .....	4-2
<b>5</b>	<b>SERVICE AND REPAIR .....</b>	<b>5-2</b>
5.1	TO CHANGE LID SEAL: .....	5-2
5.2	CHANGE SENSOR SETTINGS (IF REQUIRED) .....	5-3
<b>6</b>	<b>PARTS LIST.....</b>	<b>6-1</b>
<b>7</b>	<b>SPARE PART PRICE LIST.....</b>	<b>7-4</b>
<b>8</b>	<b>WARRANTY .....</b>	<b>8-1</b>

## **1 SCOPE OF MANUAL**

This manual contains a product description, installation, and operating instructions together with maintenance procedures for the ADS wet only atmospheric deposition sampler. A list of replacement parts, electrical schematics and wiring diagrams are also provided.

### **1.1 Purpose Of Equipment**

The ADS sampler is used to collect and composite “wet only” samples of rain, snow and other precipitation.

#### **1.1.1 General Description Of Equipment**

An infra-red detector attached to the main housing senses precipitation. An internal drive motor uncovers the sample collector and keeps it open until precipitation stops. Design of the sampler minimizes horizontal surfaces to prevent contamination due to splashing.

### **1.2 Detailed Description Of Equipment**

#### **1.2.1 Precipitation Sensor:**

An infra-red sensor detects precipitation at the rate of least one drop per minute and closes after one minute of no sensed precipitation. Design of sensor minimizes “Hunting” during marginal precipitation events.

#### **1.2.2 Housing: powder coated Aluminum rated NEMA 4X (IP65)**

#### **1.2.3 Control Panel:**

All function controls are located on a removable panel in the control housing. All electrical connections are keyed, plug-in connections. The following controls are located on the control panel:

1. Lightning and Surge Protectors.
2. Relays for precipitation and motor operation

#### **1.2.4 Drive Motor:**

Oil immersed armature and gear train.

#### **1.2.5 Moving Cover:**

Opens on start of precipitation and seals sample container when closed.

#### **1.2.6 Splash Shield:**

Prevents ground material splashing of material on to under side of cover when cover is open, also positions cover 20° below horizontal to direct any splash away from open sample container.

#### **1.2.7 AC Cable:**

#### **1.2.8 Recorder Output Cable:**

4 wire cable connects to keyed fitting on underside of sampler and is secured by a locking ring. First pair of wires provide a unpowered, normally open contact to signal when sampler is open. May be connected to the event recorder in a Belfort rain gage, as used in NADP installations. Second pair may be used to monitor line power continuity.

#### **1.2.9 System on/off switch**

NEMA 4X with 2 keys on outside of case. Turns system on or off.

#### 1.2.10 Optional DC to AC inverter:

Attaches to mounting stanchion under sampler.

Amp connector attaches to AC power in on sampler. No modification to sampler is required.

DC cable attaches to suitable rechargeable battery. **BE SURE TO OBSERVE POLARITY**

SEE INSTRUCTIONS SUPPLIED WITH INVERTER.

### 1.3 Technical Specifications

#### **SAMPLE CONTAINER:**

NADP Type  
Capacity: 3.5 US Gallons  
Material: Rigid Polyethylene, with  
carrying handle  
Cover: Snap-on lid with "O" ring seal  
Furnished: 1 each

#### **PRECIPITATION SENSOR:**

Type: Infra-red transmitter and receiver  
Opening: Within 20 seconds of onset of precipitation  
Closing: Within 2 minutes of end of precipitation  
Preset as above, but are field adjustable.

#### **DIMENSIONS:**

24" (61cm) High  
16" (41cm) Wide  
15" (38cm) Deep (less sensor)

#### **WEIGHT:**

Net: 48 Pounds (23 Kg)  
Shipping: 56 Pounds (25Kg.)

#### **MOUNTING:**

Direct mounting on 2" NPS pipe (USA)  
(2.375 Dia. 68mm Dia.)  
With mounting collar and 2 set screws

#### **MATERIALS OF CONSTRUCTION:**

: Aluminum (5052H32) .125" White powder coat

#### **OPTIONAL EXTRAS:**

See Price List

## 2 INSTALLATION SITE SELECTION

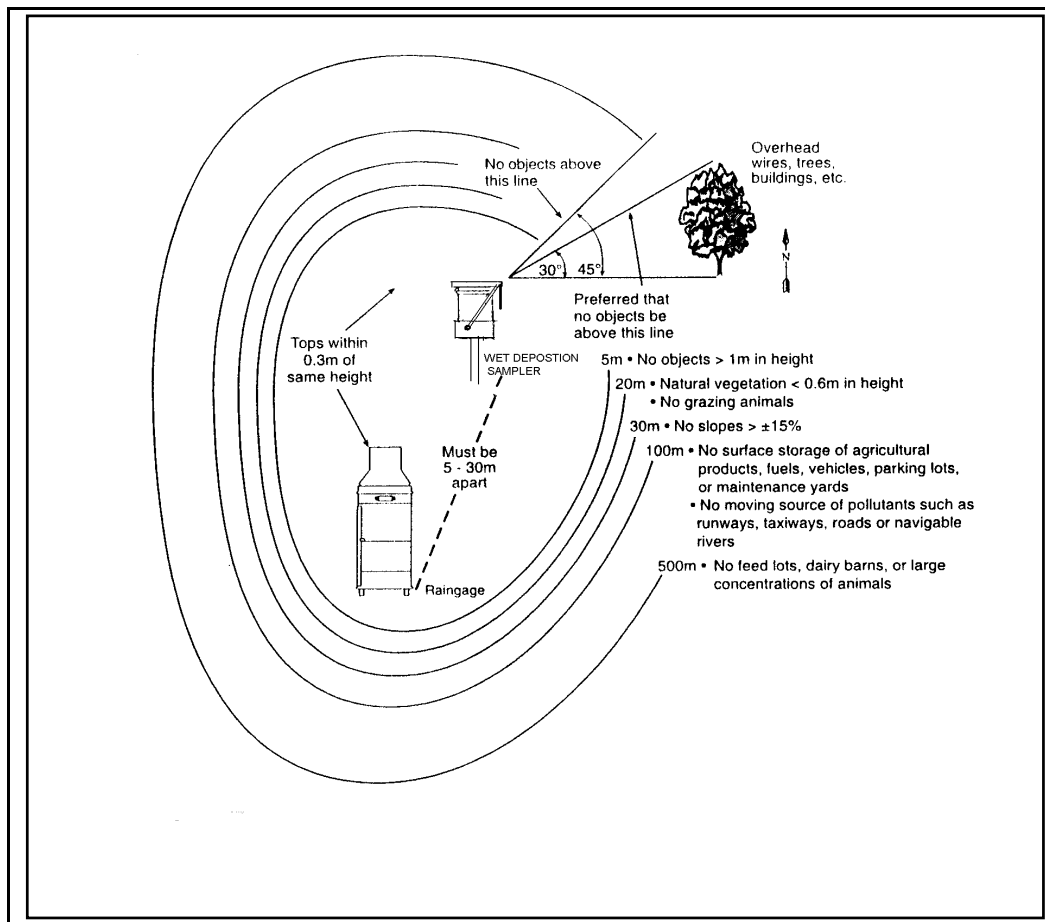

Site consideration sketch above (Courtesy of NADP) provides ideal site parameters.

## 2.1 Unpacking

The ADS sampler is packed one carton, which should be saved for reshipment.

Remove precipitation sensor and lift sampler out of carton.

## 2.2 Stanchion installation

Dig a hole, approx. 18" deep with a post hole digger.

Place stanchion (2"NPS x 60" galvanized pipe) in bottom of hole as vertical as possible, and drive into place using and a mallet a block of wood to avoid damage to open end of pipe. Use a level to assure that stanchion is vertical. Top of pipe should be approximately 36" above ground level. Tamp soil back to hold pipe. If soil conditions require it, use quick set concrete to secure it.

In areas where there is a high level of snow, stanchion should be placed on a suitable raised wooden platform with adjustable collar so that sampler may be raised. Splash shield should be maintained at least 12" above anticipated snow level.

## 2.3 Attach the splash shield:

Attach the splash shield to the support assembly with the four (4) 10-32 x 1/2" screws and lock washers.

Place the 2" NPT pipe fitting "T" end of the splash shield assembly over the top of the stanchion and lower it carefully until splash shield is about 6 inches above ground level, and secure with the set screws and Allen key provided. This will be moved up when sampler is installed and adjusted to fit the moving cover when opened.

## 2.4 Sampler Placement

Turn sampler topside up and place on top of stanchion and tighten one set screw to prevent rotation.

## 2.5 Sensor Installation

Remove the 4 nuts and lock washers that will be used to install the precipitation sensor

Hold sensor up to mounting studs and connect the keyed Molex connector to the Molex connector taped to the outside of the housing. Push the connected Molex assembly back into the housing.

Align the holes in the sensor mounting ring with the studs on the housing and secure the mounting ring to the housing with the 4 lock washer and nuts. Tighten firmly.

## 2.6 Power Connection AC

Provide a grounded, GFI controlled outlet to the sampler.

Connect the AC power cable to the socket on the underside of the sampler. Leave some slack in the cable.

To insure proper operation of lightening transient surge protectors, connection must be made to a zero resistance earth ground. In most installations it may be grounded through the mounting stanchion, however, in lightening prone area, it is advisable to ground the mounting stanchion to a copper clad earth grounding rod.

**DO NOT CONNECT TO POWER OUTLET AT THIS TIME.**

## 2.7 Power connection DC and solar charger

To operate on Battery, a DC to AC inverter (15-120) is required.

For DC operation, user must also provide two (2) 12 volt 120 amp/hr deep discharge marine batteries in a suitable outdoor housing with Two (2) 65 Watt solar panels.

## 2.8 Recorder Output Cable Installation

Connect output cable to fitting on underside of the sampler. Pair one ( Black & White) provides an unpowered closure while the sampler is open and Pair two ( Red & Green) provides an unpowered contact when line power is on. (This pair does not furnish power to the sampler)

## 2.9 Test Open Sampler

Plug in the AC power cord to the grounded, GFI controlled outlet and allow system to “warm up” for at least 5 minutes. Be sure to turn key switch to ON.

This is required to energize the precipitation sensor circuits.

To test the sensor path, wave your fingers between the arms of the sensor several times. NOTHING will happen for about a minute!

Cover will lift off container and lower to stop position.

Wait about a minute and the cover will return to cover the container.

## 2.10 Align Splash Shield

Open cover as above. When full open, turn key switch to Off.

Loosen set screw securing the splash shield assembly to the stanchion.

Rotate and raise the splash shield assembly so that the cover side edges rest on the splash shield with about ¼” on each side.

Tighten the set screws to secure the splash shield assembly to the stanchion in this position.

Turn Key switch to ON and cover will automatically close and seat on container.

Adjust the slack in the power cable so you can secure it to the stanchion.

**SECURE THE CABLE TO THE STANCHION WITH DUCT-TAPE OR A SUITABLE STRAP TO PROVIDE STRAIN RELIEF.**

## 2.11 Final Check Out

Make sure the power cord(s) are connected to underside of sampler.

Wave your fingers between sensor heads to simulate precipitation.

Observe cover opening and resting evenly on splash shield.

In about 1 minute cover should return to cover sample container.

Check that the cover seats uniformly on the container and seal is complete.

**BE SURE TO REMOVE THE KEY FROM SWITCH IN THE ON POSITION.**



### 3 OPERATION

#### 3.1 **Change Sample Container**

Following NADP protocol, approach sampler from down wind direction.

Open sampler by waving fingers between sensor heads to simulate precipitation.

Turn key switch to OFF

Remove sample container following NADP protocol.

Replace with a new sample container following NADP protocol. Be sure that the handle is toward the nameplate side of the housing.

Turn Key switch to ON and cover will immediately return to the closed position.

#### 3.2 **Bulk Sample Operation**

This procedure will be followed in the event of a power failure or failure of the sampler to open automatically.

Turn key switch to OFF.

Loosen the four (4) ¼-20 socket cap screws in motor drive (lower end of drive arm).

Swing the cover up and to fully open position, resting on splash shield.

**NOTE: IF POWER FAILURE OCCURS WHILE SAMPLER IS OPENING OR CLOSING, RESTORATION OF POWER WILL RETURN MOTOR DRIVE AXEL TO THE CLOSED POSITION.**

To return to automatic operation, swing cover assembly to closed position with cover on top of container. Press cover down firmly and retighten the socket cap screws on the motor drive end of the arms.

**DO NOT RETURN COVER TO CLOSE BUCKET UNTIL YOU ARE SURE POWER HAS BEEN RESTORED.**

#### 3.3 **Align Moving Cover**

If cover is not seating firmly on top of bucket, when closed. Open sampler, turn switch off and back on.

When the forward edge of the cover seal is about a half inch above the bucket, turn switch off . Loosen the 4 1/4-20 cap screws in the axel end of arms. Press the cover down firmly on the sample bucket and while holding cover in place, re tighten the 4 cap screws on the axels. Turn power on again and check alignment. Repeat if necessary.

## **4 DRAWINGS AND ILLUSTRATIONS**

### **4.1 Drawings**

4.1.1	General arrangement	D120-M1
4.1.2	Electrical schematic	D120-E1 rev.A
4.1.3	Wiring diagram, input	D120-E2 rev A
4.1.4	Wiring diagram, control	D120-E3 rev A
4.1.5	Connection cables	D120-E4 rev A
4.1.6	Wiring diagram, motor	D120-E5 rev A
4.1.7	Wiring diagram, sensor	D125-5
4.1.8	General arrangement, Inverter	D120-E7
4.1.9	Wiring diagram, Inverter	D120-E8

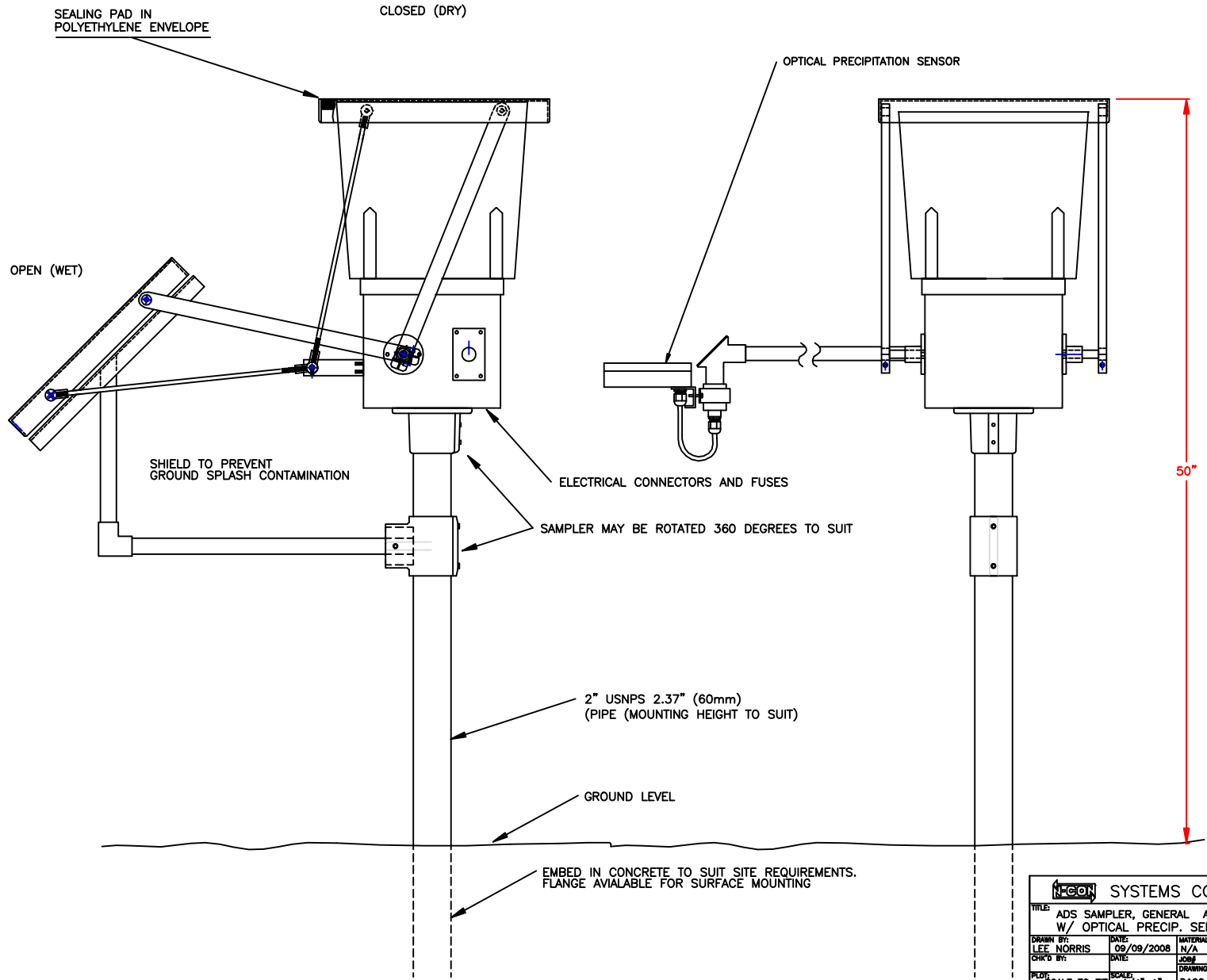

<b>NECON SYSTEMS CO., INC.</b>			
TITLE: ADS SAMPLER, GENERAL ARRANGEMENT W/ OPTICAL PRECIP. SENSOR			
DRAWN BY: LEE NORRIS	DATE: 09/09/2008	MATERIAL: N/A	
CHK'D BY:	DATE:	JOB#	
PLT:	SCALE: SCALE TO FIT	DRAWING NO. D120-M1	

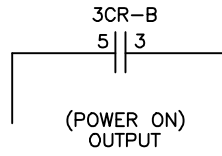
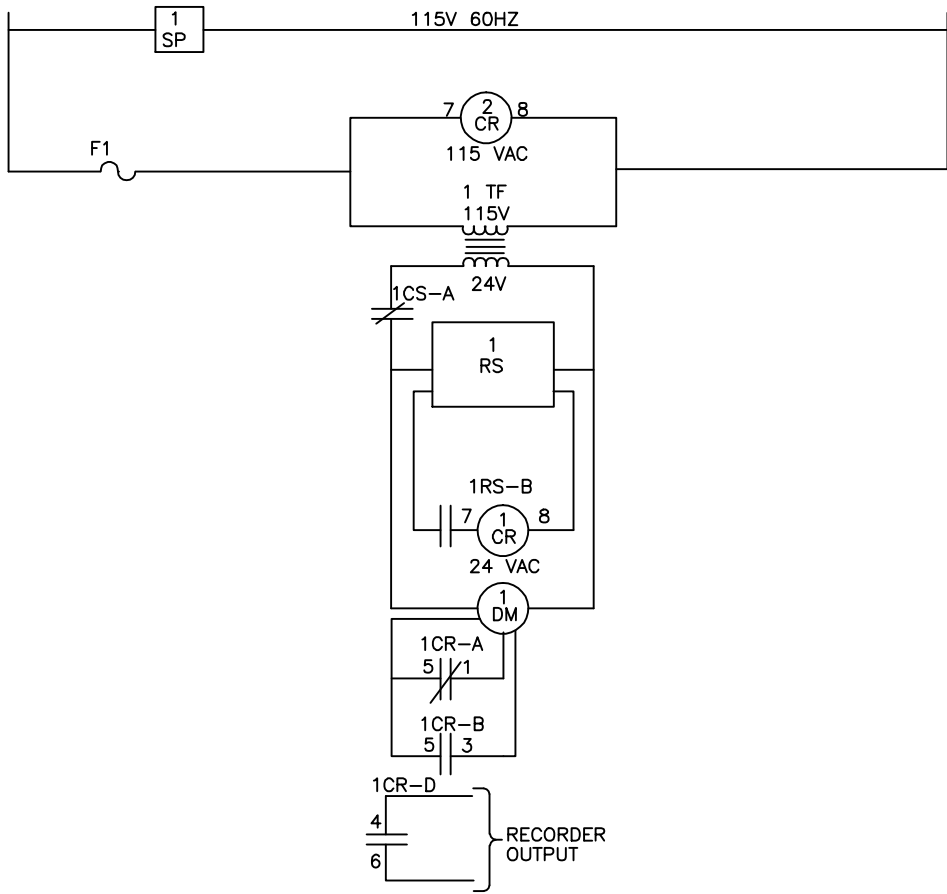

 SYSTEMS CO., INC.

TITLE: ADS SAMPLER ELECTRICAL SCHEMATIC		
DRAWN BY: LEE NORRIS	DATE: 06/04/2010	MATERIAL: N/A
CHK'D BY:	DATE:	JOB# N/A
PLOT: 1:1 (11 x 8.5)	SCALE: 1"=1"	DRAWING NO. D120-E1 REV-A

LEGEND: A=ADDED W=WAS D=DELETED R=REVISED				
REV	DESCRIPTION	DATE	DR.	APPR.
A	RELEASE TO PRODUCTION	06/04/2010	LN	MIB

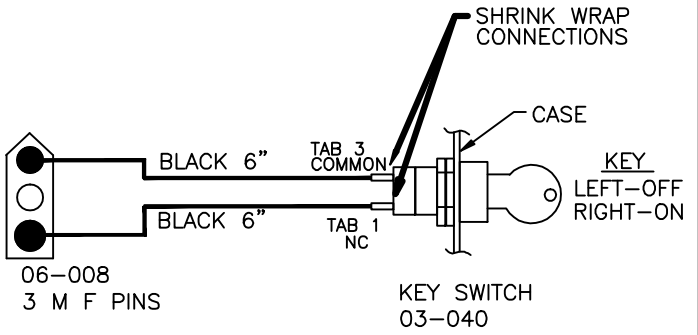
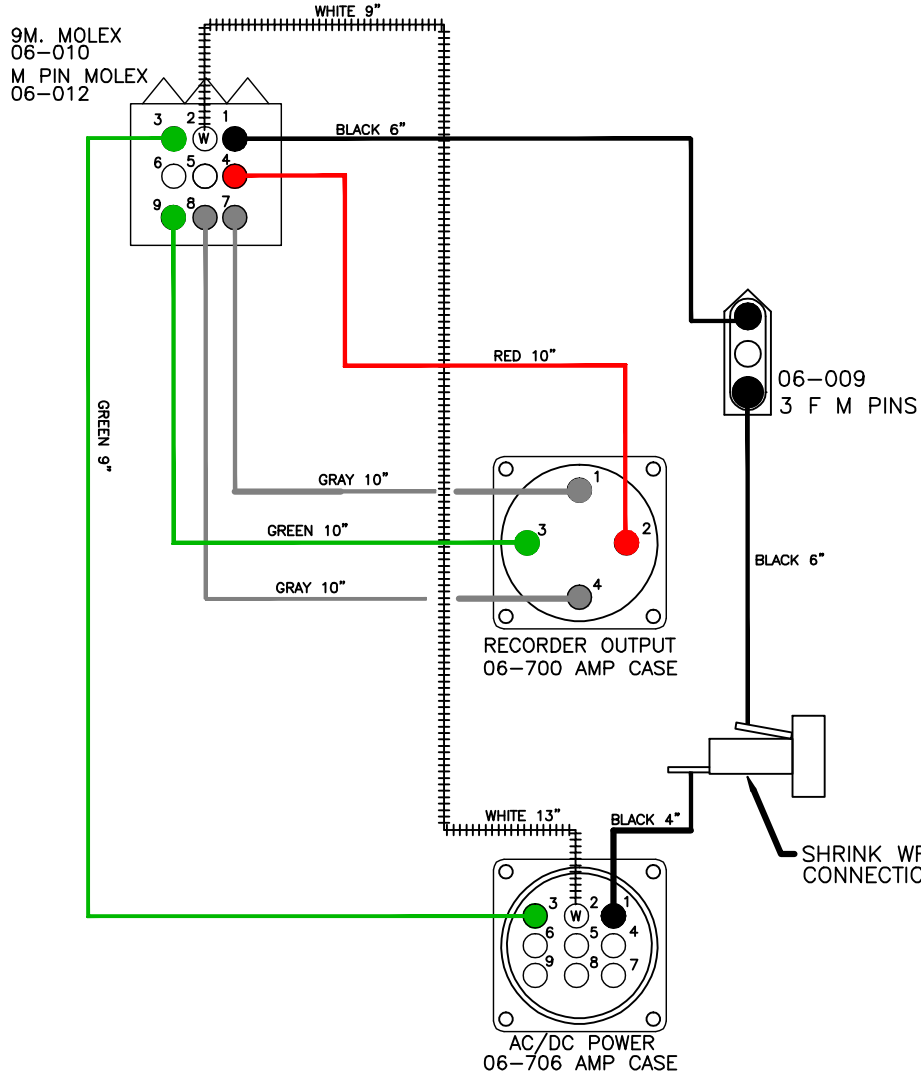

06-168  
FUSEHOLDER  
06-031  
FUSE (10 AMP)

SYSTEMS CO., INC.		
TITLE: ADS SAMPLER, NTN, INPUT WIRING DIAGRAM		
DRAWN BY: LEE NORRIS	DATE: 06/04/2010	MATERIAL: N/A
CHK'D BY:	DATE:	JOB# N/A
PLOT: 11x17 (1:1)	SCALE: 1"=1"	DRAWING NO. D120-E2 REV-A

RELAY CLOSES TO OPEN COVER & SEND UNPOWERED SIGNAL TO DATA OUTPUT CABLE.

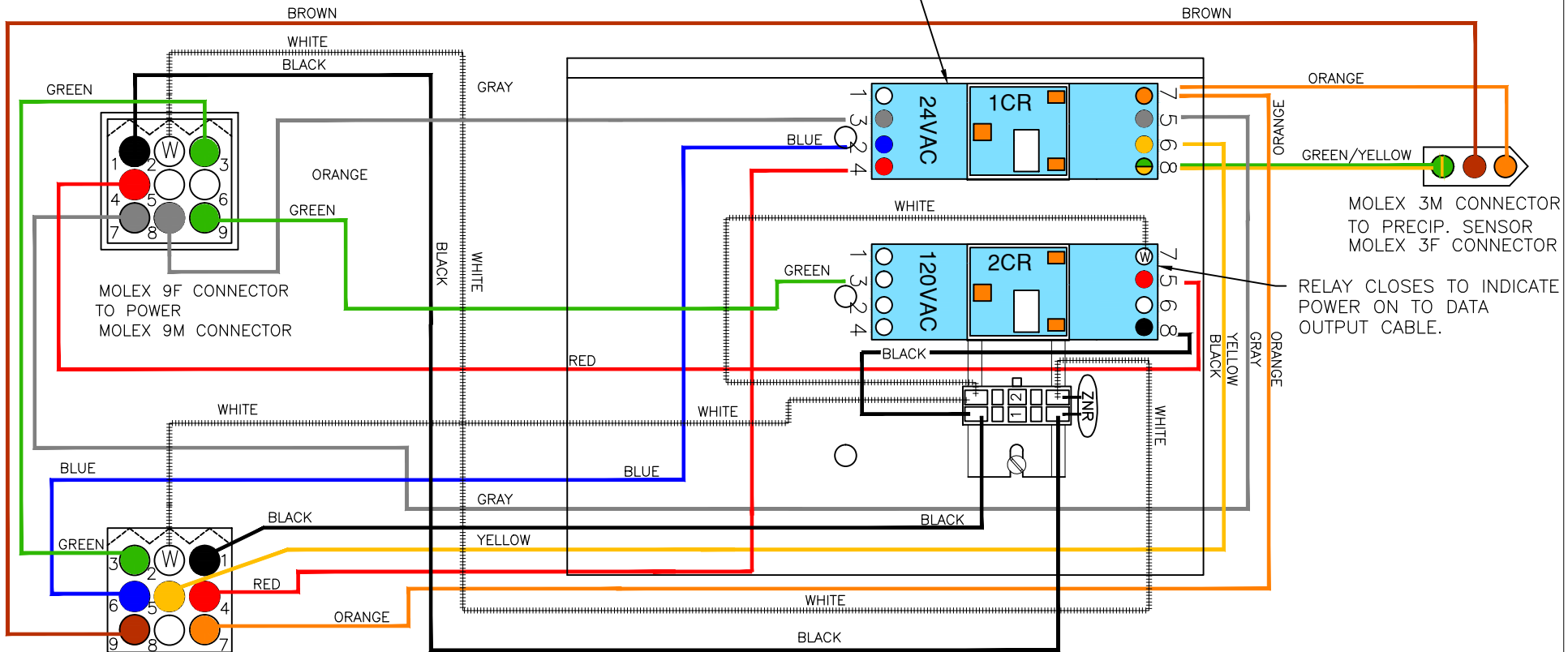

MOLEX 3M CONNECTOR TO PRECIP. SENSOR MOLEX 3F CONNECTOR

RELAY CLOSES TO INDICATE POWER ON TO DATA OUTPUT CABLE.

MOLEX 9F CONNECTOR TO POWER MOLEX 9M CONNECTOR

MOLEX 9M CONNECTOR TO MOTOR MOLEX 9F CONNECTOR

 SYSTEMS CO., INC.		
TITLE: ADS SAMPLER, CONTROL WIRING DIAGRAM		
DRAWN BY: LEE NORRIS	DATE: 03/04/2011	MATERIAL: N/A
CHK'D BY:	DATE:	JOB# N/A
PLOT: B SIZE 11x17	SCALE: 3/4"=1"	DRAWING NO. D120-E3 REV-C

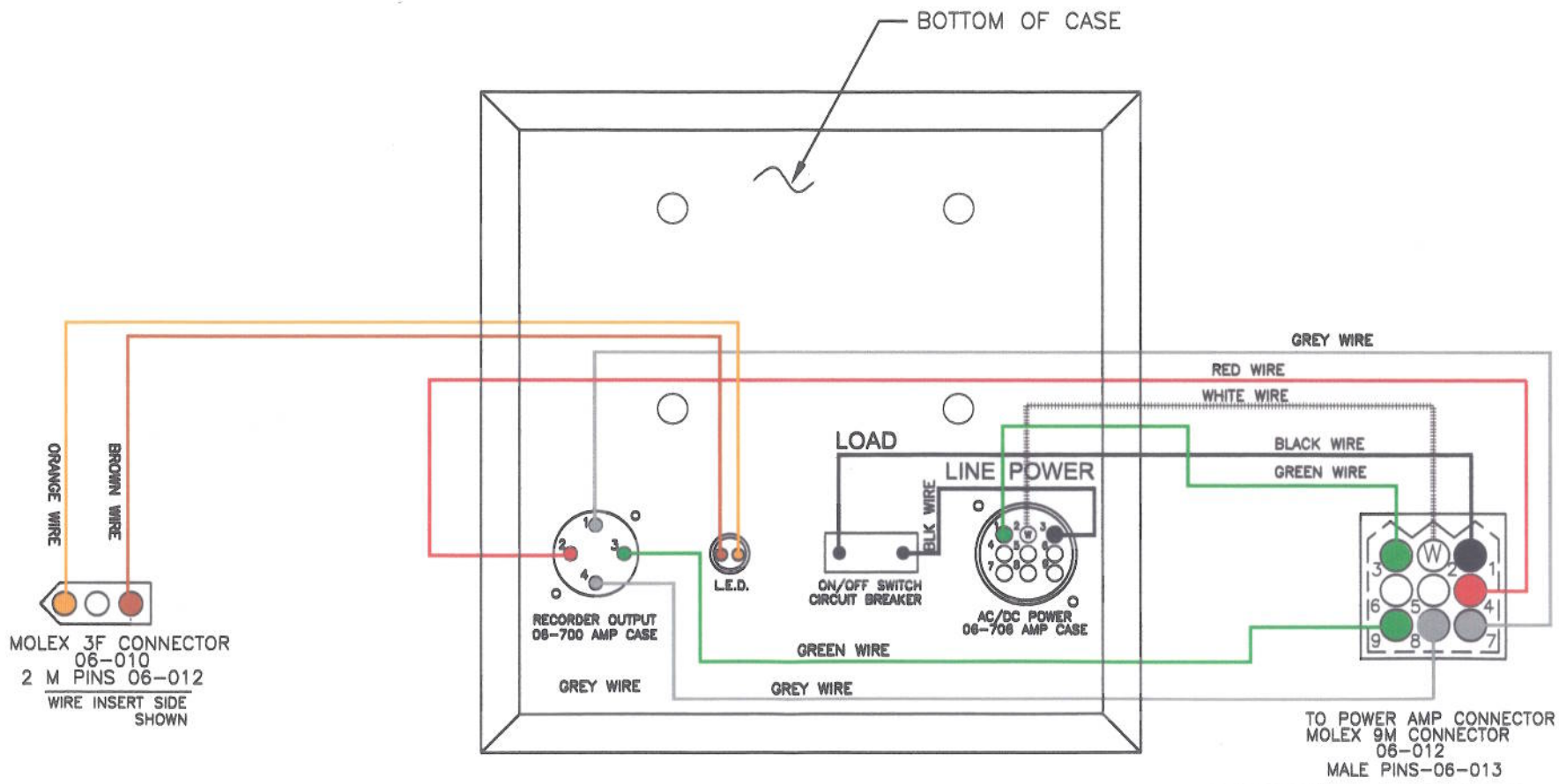

LOOKING INSIDE CASE FROM TOP

MOLEX 3F CONNECTOR  
06-010  
2 M PINS 06-012  
WIRE INSERT SIDE  
SHOWN

TO POWER AMP CONNECTOR  
MOLEX 9M CONNECTOR  
06-012  
MALE PINS-06-013

<b>NECON SYSTEMS CO., INC.</b>		
TITLE: ADS SAMPLER, HOUSING WIRING DIAGRAM		
DRAWN BY: LEE NORRIS	DATE: 06/06/2011	MATERIAL: N/A
CHK'D BY:	DATE:	JOB# N/A
PLOT: B SIZE 11x17	SCALE: 3/4"=1"	DRAWING NO. D120-EB REV A

IN-HOUSE D120-EB REV A

PART NO: 15-418  
DATA CABLE

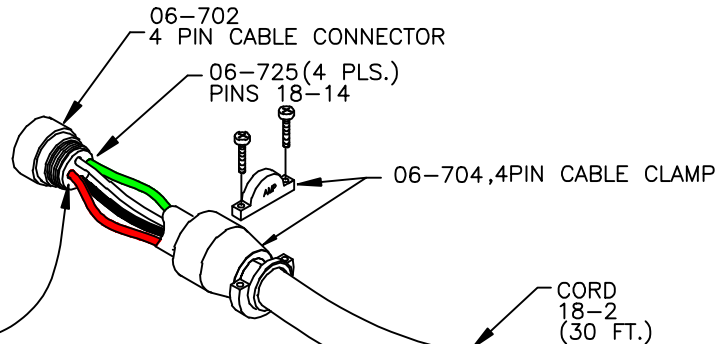
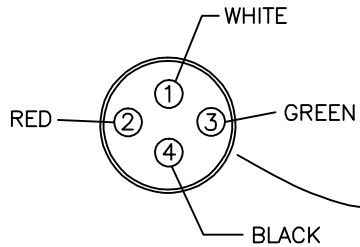

CORD  
18-2  
(30 FT.)

BLACK AND WHITE UNPOWERED TO  
RAIN GAUGE DATA LOGGER TO  
INDICATE SAMPLER COVER OPEN.

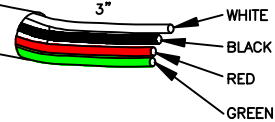

RED AND GREEN UNPOWERED CONTACT  
TO INDICATE POWER IS ON TO SAMPLER  
AND DATA LOGGER.

PART NO: 15-504  
AC CABLE (115VAC)

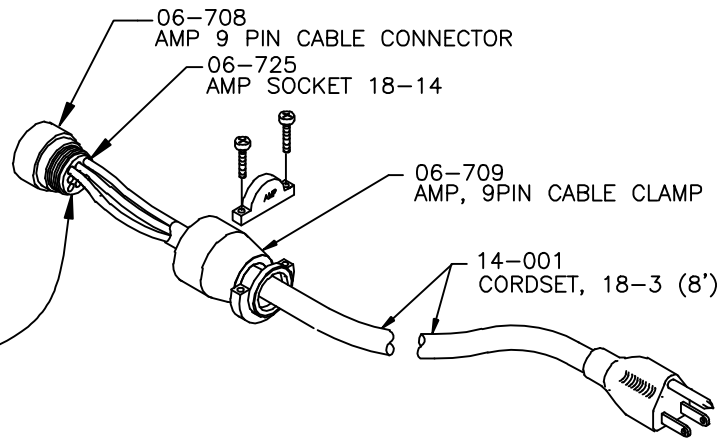
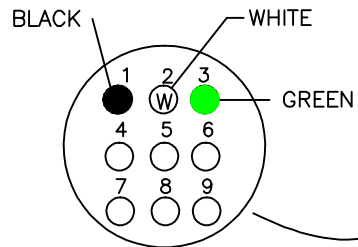



14-001  
CORDSET, 18-3 (8')

 SYSTEMS CO., INC.		
TITLE: ADS SAMPLER, CONNECTION CABLES		
DRAWN BY: LEE NORRIS	DATE: 06/04/2010	MATERIAL: N/A
CHK'D BY:	DATE:	JOB# N/A
PLOT:	SCALE: 3/8"=1"	DRAWING NO. D120-E4 REV-A
1:2.66667		

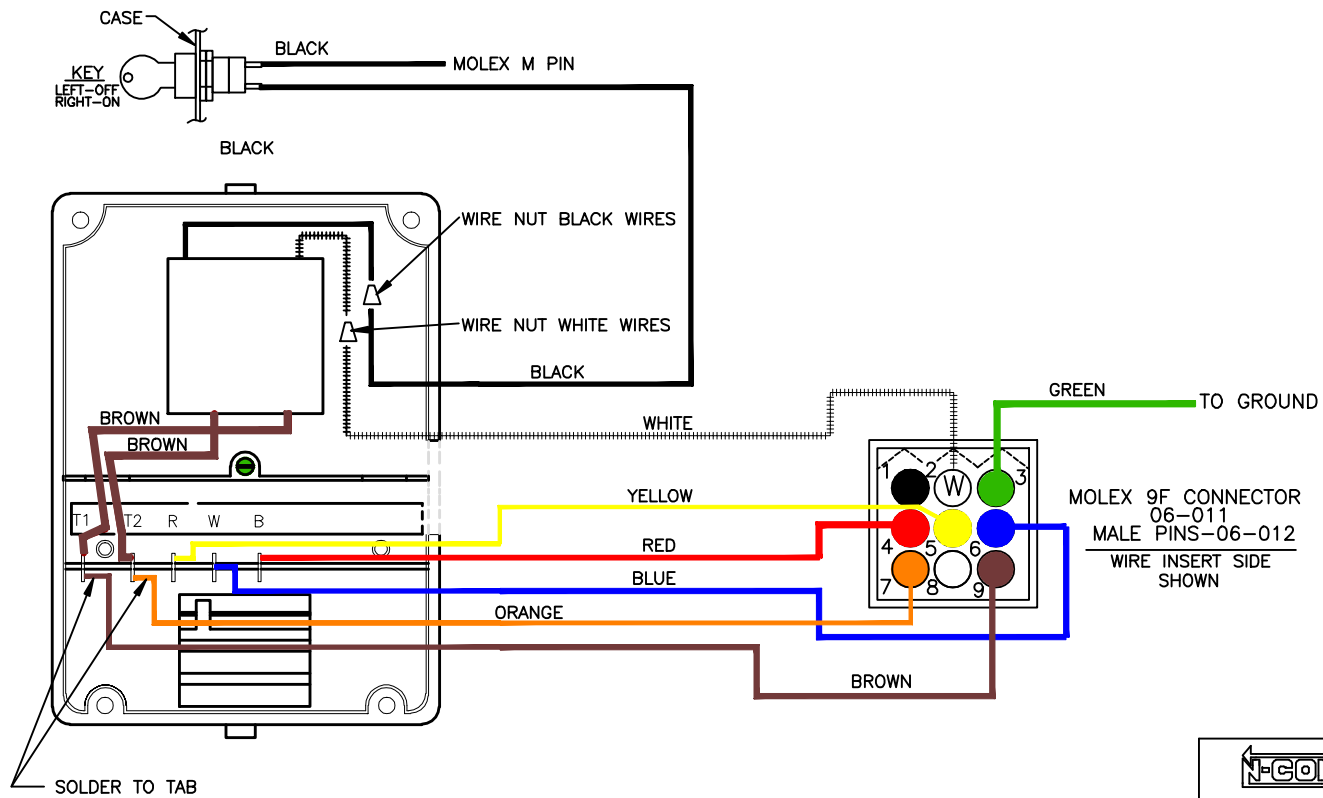

LEGEND: A=ADDED W=WAS D=DELETED R=REVISED				
REV	DESCRIPTION	DATE	DR.	APPR.



 <b>SYSTEMS CO., INC.</b>		
<b>TITLE:</b> ADS SAMPLER, MOTOR WIRING		
<b>DRAWN BY:</b> LEE NORRIS	<b>DATE:</b> 9/9/2008	<b>MATERIAL:</b> N/A
<b>CHK'D BY:</b>	<b>DATE:</b>	<b>JOB#</b> N/A
<b>PLOT:</b> 11x8.5 SCALE TO FIT	<b>SCALE:</b> 1/2"=1"	<b>DRAWING NO.</b> D120-E5

LEGEND: A=ADDED W=WAS D=DELETED R=REVISED				
REV	DESCRIPTION	DATE	DR.	APPR.

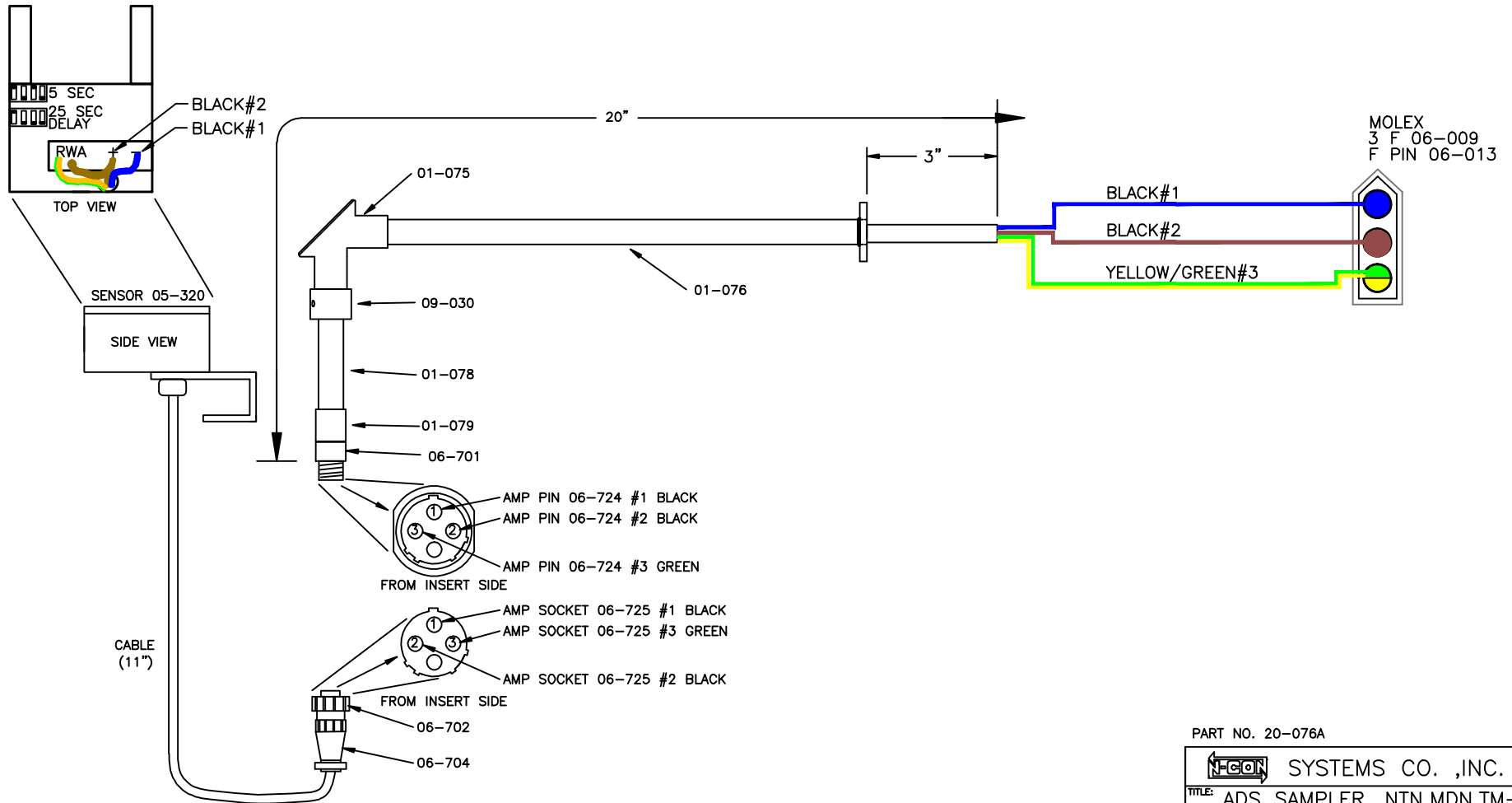

PART NO. 20-076A

 SYSTEMS CO., INC.		
<b>TITLE:</b> ADS SAMPLER, NTN,MDN,TM- SENSOR ATTACHMENT ASSEMBLY		
<b>DRAWN BY:</b> LEE NORRIS	<b>DATE:</b> 07/19/2010	<b>MATERIAL:</b> N/A
<b>CHK'D BY:</b>	<b>DATE:</b>	<b>JOB#</b>
<b>PLOT:</b> 11x17 (SCALE TO FIT)	<b>SCALE:</b> NONE (1/2"=1" FORM)	<b>DRAWING NO.</b> 00125-5

LEGEND: A=ADDED W=WAS D=DELETED R=REVISED				
REV	DESCRIPTION	DATE	DR.	APPR.

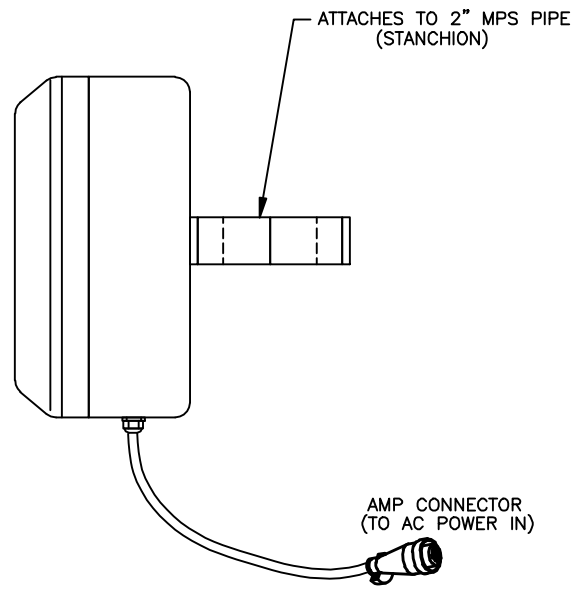
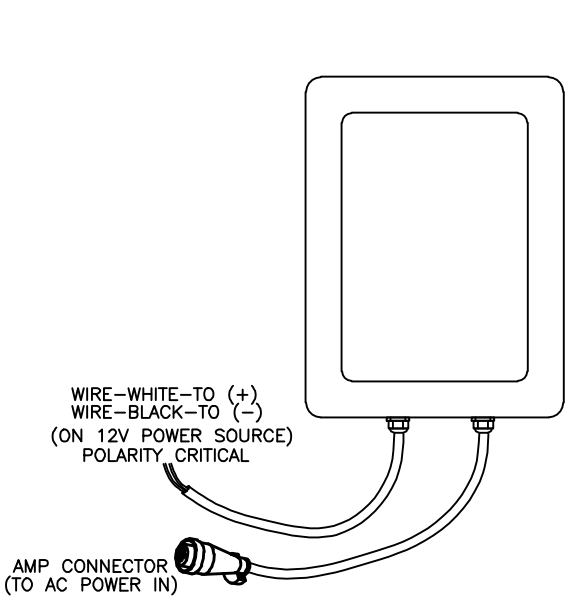

DO NOT SCALE (DRAWING NOT PRINTED TO SCALE)

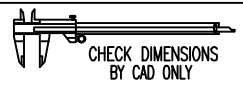

 SYSTEMS CO., INC.		
TITLE: ADS NTN SAMPLER, GENERAL ARRANGEMENT, INVERTER		
DRAWN BY: LEE NORRIS	DATE: 08/30/2008	MATERIAL: PVC
CHK'D BY:	DATE:	JOB# N/A
PLOT:	SCALE: 1/2"=1"	DRAWING NO. D 120-E7
11x8.5		

# 12 volt DC to 120VAC INVERTER

PART# 15-120

The inverter assembly is designed to convert 12volt DC power to 120VAC to operate an N-CON Systems ADS/NTN precipitation sampler.

The inverter assembly is easily attached to the 2" NPT pipe that supports the ADS/NTN precipitation sampler.

1. Loosen the two hex head bolts holding the clamp and remove clamp half.
  2. Place the clamp around the support pipe with the connector wires facing down, and replace two hex head bolts to secure clamp.
  3. When ready to connect power cables, raise the box up under the sampler and secure by tightening the two hex head bolts.
  4. Connect the cable connector to the power input connector on the bottom of the sampler. Connect the Black wire on the battery cable to (-) and the White wire to ( + )  
Be sure polarity is correct: Black to NEGATIVE White to POSITIVE or inverter will not work.
- **BE SURE TO USE ONLY Deep Discharge Marine or RV Batteries.**
  - **Do not use automobile batteries.**

## SUGGESTED SOLAR CHARGER/STORAGE BATTERY SYSTEM

For N-CON Systems Co. Inc. ADS/NTN Precipitation Samplers

Item #	Model #	Description:
201160	SE-4000	Solar panel, 65Watts
201163	11100	Charge controller.
201413	DC31	Battery, 120 amp/hr Deep Discharge *

Source: Defender Industries,  
45 Great Neck Road  
Waterford, CT 06385-3336

Phone: 800-628-8225

URL [www.defender.com](http://www.defender.com)

N-CON SYSTEMS DOES NOT BEAR RESPONSIBILITY FOR SPECIFICATION OF BATTERIES OR SOLAR CHARGERS.

THE ABOVE IS FOR INFORMATION ONLY

CHECK FOR LOCAL SOURCES AND SPECIFICATIONS

## **4.2 Illustrations**

- 4.2.1 Over all view sampler closed
- 4.2.2 Over all view sampler opened

OVER ALL VIEW: SAMPLER CLOSED



OVER ALL VIEW, SAMPLER OPEN



## **5 SERVICE AND REPAIR**

### **5.1 To Change Lid Seal:**

- 5.1.1 Open the sampler by passing fingers between the sensor.
- 5.1.2 When sampler is about half way opened, turn off switch.
- 5.1.3 Loosen the wing nuts to release clamps. Stop nuts should not be removed as they prevent loss of wing nuts!
- 5.1.4 Remove seal pad.
- 5.1.5 With the attachment tape on the underside of pad facing the front and back, install new seal pad by sliding end under the clamp and secure with the wing nuts.
- 5.1.6 Be sure the seal pad is smooth the pad against the underside of the lid .
- 5.1.7 Wipe the seal with a lint free cloth dampened with de-ionized or distilled water.
- 5.1.8 Be sure sample container is in place.
- 5.1.9 Turn switch on again and sampler will close.
- 5.1.10 When sampler closes, check that the lid seal is properly in place to seal the container. If cover requires adjustment, see section: 3-3.



## 5.2 Change Sensor settings (if required)

DIP – switch-off delay ( 1 = on 0 = off)                      DIP switch – drop incidences –

S1	S2	S3	S4	Time (sec)	S1	S2	S3	S4	drops
1	0	0	0	25*	1	0	0	0	1
0	1	0	0	50	0	1	0	0	2
1	1	0	0	75	1	1	0	0	3
0	0	1	0	100	0	0	1	0	4
1	0	1	0	125	1	0	1	0	5 *
0	1	1	0	150	0	1	1	0	6

DIP – switch adjustment

Factory settings:        switch off delay        25 sec.  
                                 drop incidences:        5

If this setting is to be changed, the **switch-off delay**, and the number of **drop incidences** are set through the DIP-switches acc. to the table.

DIP – switch for switch-off delay

DIP switch for drop incidences

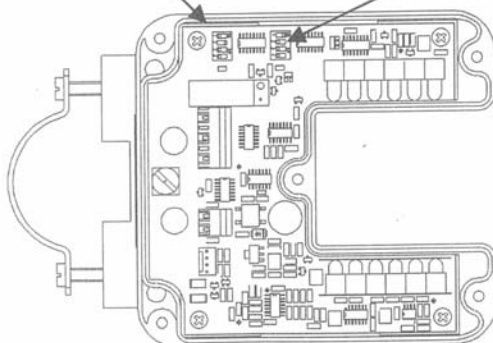

Figure 1: DIP - switch

## 6 PARTS LIST

ITEM #	NAME: Description	ASSEMBLY #	COMPONENT #	INDIVIDUAL Part #	QUANTITY.
<b>1-0</b>	<b>Cover, Housing Assembly</b>	<b>20-071</b>	--	--	<b>1</b>
1-1	Cover, Housing	--	01-071	--	1
1-2	Gasket, Cover	--	16-121	--	1
1-3	Support, Container	--	09-056	--	4
1-4	Screw, 10-32X1/2 FHSS	--	23-1032-08-2	--	4
1-5	Screw, 10-32 x ¼ BHSS	--	23-1032-04-1	--	2
1-6	Lock Washer #10	--	23-1032-93-0	--	2
1-7	Hold down, bucket	--	01-077	--	1
1-8	Keeper, Latch	--	01-850-1	--	2
1-9	Screw, 8-32 1/4 FHSS	--	23-0832-04-2	--	2
<b>2-0</b>	<b>Housing Assembly</b>	<b>20-072</b>	--	--	<b>1</b>
2-1	Housing, Control	--	01-070	--	1
2-2	Mounting Flange, 2" Pipe	--	01-065	--	1
2-3	Bolt, Hex, 3/8" X 1"	--	23-3816-16-4	--	4
2-4	Nut, Hex 3/8"	--	23-3816-91-0	--	4
2-5	Washer, 3/8"	--	23-3816-92-0	--	4
2-6	Latch	--	01-850	--	2
2-7	Screw, 8-32 X ¼"	--	23-0832-04-1	--	2
2-8	Lock Washer, #8	--	23-0832-93-0	--	2
2-9	Screw, 10-32 1" BHSS	--	23-1032-16-1	--	4
2-10	Gasket, Sensor Support	--	16-036	--	1
2-11	Wing nut, 10-32	--	23-1032-91-3	--	4
2-12	Lock Washer, #10	--	23-1032-93-0	--	4
2-13	Bearing, Housing ADS Arm	--	09-121	--	2
2-14	Gasket, bearing	--	16-120	--	4
2-15	Screw, 10-32 x 5/8	--	23-1032-10-1	--	4
2-16	Support, outboard axel	--	19-147	--	2
2-17	Screw, 10-32 x1/2	--	23-1032-08-1	--	4
2-18	Lock washer, #10	--	23-1032-93	--	4
2-19	Support axel	--	09-088	--	1
2-20	10-32 x ¼ set screw	--	23-1032-04-5	--	2
2-21	Key switch –ON/OFF With 2 keys 400R	--	03-040	--	1
<b>3-0</b>	<b>Motor Assembly</b>	<b>20-073</b>	--	--	<b>1</b>
3-1	Motor	--	07-250	--	1
3-2	Transformer	--	07-255	--	1
3-3	Mounting bracket	--	07-251	--	1
3-4	Push on Terminal, insulated	--	23-4-1625	--	3
3-5	Molex 9 Pin Female	--	06-011	--	1
3-6	Molex Pin, Male	--	06-012	--	9

ITEM #	NAME: Description	ASSEMBLY #	COMPONENT #	INDIVIDUAL Part #	QUANTITY.
<b>4-0</b>	<b>Arm Assembly</b>	<b>20-074</b>	--	--	<b>2</b>
4-1	Arm, ADS Cover	--	09-122	--	2
4-2	Axel, Motor Drive	--	09-130	--	2
4-3	Bearing, Cover ADS	--	09-123	--	4
4-4	Gasket, Housing Bearing	--	16-120	--	4
4-5	Screw, 10-32x1-Sock. Cap	--	23-1032-16-4	--	2
4-6	Arm, support	--	09-146	--	2
4-7	Rod end, right hand	--	09-142	--	2
4-8	Rod end, Left hand	--	09-143	--	2
4-9	Shoulder screw, 10-32 x 3/8	--	09-081	--	4
4-10	Nut, 1/4-28 bronze right hand	--	23-1428-91-0	--	2
4-11	Nut, 1/4-28 left hand	--	23-1428-91-1	--	2
4-12	Elastic stop nut, 10-32	--	23-1032-91-7	--	4
4-13	Screw, 1/4-20 x 3/4 socket cap	--	23-1420-12-4	--	4
<b>5.0</b>	<b>Container Cover Assembly</b>	<b>20-075</b>	--	--	<b>1</b>
5-1	Cover, Moving	--	01-051	--	1
5-2	Lid Seal, Moving Cover	--	16-122	--	1
5-3	Lid seal clamp	--	16-125	--	2
5-4	Screws, 8-32 x 2" truss head	--	23-0832-32	--	4
5-5	Wing nut, 8-32	--	23-0832-91-3	--	4
5-6	Stop nut, 8-32	--	23-0832-95-0	--	4
5-7	Shoulder screw 10-32 x 1"	--	09-083	--	2
<b>6-0</b>	<b>Sensor Assembly</b>	<b>20-076</b>	--	--	<b>1</b>
6-1	Sensor, Precipitation	--	05-320	--	1
6-3	Attachment For Sensor	--	01-076	--	1
6-4	Molex, 3 Pin Female	--	06-009	--	1
6-5	Molex Pin, Female	--	06-013	--	3
6-6	Amp 4 pin free hanging	--	06-701	--	1
6-7	Amp pin	--	06-724	--	3
6-8	Amp 4 pin cable connector	--	06-702	--	1
6-9	Amp 4 pin cable clamp	--	06-704	--	1
6-10	Amp socket	--	06-725	--	3
<b>7-0</b>	<b>Control Assembly</b>	<b>20-077</b>	--	--	<b>1</b>
7-1	Chassis	--	01-041	--	1
7-2	Din Rail, 3.25"	--	06-512-3	--	1
7-3	Screw, 8-32x 1/4 BHSS	--	23-0832-04-1	--	6
7-4	Socket, Relay	--	04-126	--	2
7-7	Relay, DPDT 24VAC	--	04-125	--	1
7-8	Relay, DPDT 115VAC	--	04-129	--	1
7-9	Surge Protector	--	15-129	--	1
7-10	Terminal block	--	06-504	--	1
7-11	Screw, 10-32 X 5/8 Seal	--	23-1032-10-8	--	1
7-12	Molex, 3 Pin Male	--	06-008	--	1
7-13	Molex Pin, Male	--	06-012	--	3
7-14	Molex, 9 pin Male	--	06-010	--	1
7-15	Molex, 9 Pin Female	--	06-009	--	1
7-16	Molex Pin, Female	--	06-013	--	17

ITEM #	NAME: Description	ASSEMBLY #	COMPONENT #	INDIVIDUAL Part #	QUANTITY
<b>8-0</b>	<b>Splash Shield Assembly</b>	<b>20-078</b>	--	--	<b>1</b>
8-1	Splash Shield	--	01-056	--	1
8-2	Support, horizontal (15.0")	--	01-074H	--	1
8-3	Support, vertical (12.375")	--	01-074V	--	1
8-4	T, 3 Outlet Shield Support	--	01-058	--	1
8-5	Plug, Splash Shield Support	--	01-072	--	1
8-6	Set Screw, ¼-20	--	23-1420-04-5	--	1
8-7	Screw, 10-32x1/2	--	23-1032-08-1	--	2
8-8	Swivel Flange	--	01-048	--	1
<b>9-0</b>	<b>Power in-put Assembly</b>	<b>20-079</b>	--	--	<b>1</b>
9-1	AMP Connector, 9 Pin Case	--	06-706	--	1
9-2	AMP Pin	--	06-724	--	5
9-3	Screw, 4-40x1/2	--	23-0440-08-1	--	4
9-4	Nut, 4-4-	--	23-0440-91-0	--	4
9-5	Lock Washer, #4	--	23-0440-93-0	--	4
9-6	Molex 3 Pin Male	--	06-008	--	2
9-7	Molex Pin, Male	--	06-012	--	5
<b>10-0</b>	<b>Data logger output Assembly</b>	<b>20-080</b>	--	--	<b>1</b>
10-1	AMP 4 Pin Case Connector	--	06-700	--	1
10-3	Amp Pin	--	06-724	--	2
10-4	Screw, 4-40x1/2	--	23-0440-08-1	--	4
10-5	Nut, 4-40	--	23-0440-91-0	--	4
10-6	Lock Washer #4	--	23-0440-93-0	--	4
10-7	Molex 4 Pin Female	--	06-005	--	1
10-8	Molex Pin, Female	--	06-013	--	4
	AC Power Cable	--	--	15-504	1
	Out-Put Signal Cable	--	--	15-418	1
	Sample Container, 3.5 Gal.	--	--	19-500	1
	Sample Container Cover	--	--	19-501	1
<b>11-0</b>	<b>DC TO AC Inverter OPTIONAL</b>	<b>15-120</b>	--	--	<b>1</b>
11-1	Inverter 150 W 12vdc/120vac	--	15-125	--	1
11-2	Case, inverter assembly	--	01-120	--	1
11-3	Chassis, inverter	--	01-121	--	1
11-4	Inverter clamp	--	01-124	--	1
11-5	8-32 x ¼-BHSS	--	23-0832-04-1	--	2
11-6	10-32 x ½ BHSS	--	23-1032-08-1	--	4
11-7	Cable grip ½ npt .25 cable	--	06-066	--	2
11-8	Amp 9pin cable connector	--	06-708	--	1
11-9	Amp 9pin cable clamp	--	06-709	--	1
11-10	Amp socket	--	06-725	--	3
11-11	Stanchion clamp, inverter	--	01-123	--	1
11-12	Flat plug, inverter	--	15-225	--	1

## 7 SPARE PART PRICE LIST

00-125-5	Precipitation Sensor Assembly optical	\$ 1,375.00
04-125	Relay, 2 pole double throw, 24 VAC	30.00
04-129	Relay, 2 pole double throw, 115VAC (domestic)	30.00
04-120	Relay, 2 pole double throw, 240VAC (overseas)	32.50
07-250-90	Motor, cover drive, bi-directional	825.00
07-252	Transformer, ADS motor	123.75
09-081	Shoulder screw. 3/8"	5.00
09-083	Shoulder screw, 1"	6.00
15-418	Data logger out-put cable	65.00
15-504	AC power cable	25.00
16-122	Lid seal, Moving Cover (for sample container)	42.50
19-500	Sample container, 3.5 gal. NADP type with cover	32.50
22-120	Manual, ADS Atmospheric Deposition Sampler	20.00
23-0832-91-3	Wing nut 8-32	1.25
23-1032-95-0	Elastic Stop nut – 8-32	1.50
23-1032-91-3	Wing nut 10-32	1.50
23-1420-16-4	¼-20" Socket head cap screw, (arm attachment)	1.75

Prices subject to change without notice. Please contact N-Con Systems Co., Inc. for current prices or parts that are not listed above.

## **8 WARRANTY**

### **N-CON SYSTEMS CO., INC. WARRANTY**

#### **WHAT IS COVERED**

N-CON Systems, Co. Inc. warrants that the product you have purchased will be free of defects in materials and workmanship.

#### **FOR HOW LONG**

This warranty covers all defects that you bring to the attention of N-CON Systems within ONE YEAR FROM DATE OF PURCHASE.

#### **WHAT N-CON SYSTEMS WILL DO**

If your N-CON product is defective we will repair or replace it and will ship it back (UPS Ground) to you free of charge. If UPS Blue or RED air is required, you will be charged the difference between air service and ground service to the same destination.

#### **HOW TO GET SERVICE**

Please call 1-800-932-6266 to OBTAIN RETURN AUTHORIZATION. You must return your N-CON product within one year of the date of purchase, shipping prepaid, to our factory at this address:

N-CON Systems Company, Inc.  
(Mail & Purchase Orders: P.O. Box 809)  
Warranty Repair Service  
180 North Street  
Crawford, GA 30630

In any correspondence with us, or if you send part but not all of the product, please include both Model and Serial # of the product.

#### **WHAT THIS WARRANTY DOES NOT COVER**

Your rights and remedies are specifically limited to those set forth in this warranty. N-CON Systems disclaims any and all implied warranties including those of mercantability or fitness for a specific purpose. N-CON Systems shall not be liable for any special, incidental, or consequential damages. In no event shall N-CON Systems liability to you exceed the purchase of your N-CON product.