

NADP Manual 1999-01c (revised)

NATIONAL TRENDS NETWORK SITE OPERATION MANUAL

NATIONAL ATMOSPHERIC DEPOSITION PROGRAM

A Cooperative Research Support Program of the
State Agricultural Experiment Stations (NRSP-3)
Federal and State Agencies
and Private Research Organizations



**For information about the
National Atmospheric Deposition Program (NADP), contact:**

**NADP Program Office
Illinois State Water Survey
2204 Griffith Drive
Champaign, IL 61820-7495**

NADP Home Page: <http://nadp.sws.uiuc.edu>
E-mail: nadp@sws.uiuc.edu

NATIONAL TRENDS NETWORK SITE OPERATION MANUAL

**prepared by Scotty R. Dossett and Van C. Bowersox
NATIONAL ATMOSPHERIC DEPOSITION PROGRAM
Illinois State Water Survey
2204 Griffith Drive
Champaign, Illinois 61820-7495
July 1999**

Dossett, Scotty R., and Van C. Bowersox. 1999. *National Trends Network Site Operation Manual*. National Atmospheric Deposition Program Office at the Illinois State Water Survey. NADP Manual 1999-01. Champaign, IL.

This manual was printed on recycled and recyclable papers

CONTENTS

1	Introduction	1-1
1.1	Atmospheric Deposition: Why Be Concerned?	1-1
1.2	NADP Monitoring: Program History and Objectives	1-2
1.3	NADP Status: Current and Future	1-3
1.4	References	1-6
2	National Trends Network Monitoring Program	2-1
2.1	NTN Monitoring Strategy	2-1
2.2	Site Selection	2-1
2.3	Field Site Operations	2-2
2.3.1	The Standard Sampling Period	2-5
2.3.2	Sample Types	2-5
2.3.2.1	Wet-Deposition-Only Sample	2-5
2.3.2.2	Bulk Sample	2-5
2.3.2.3	Undefined Sample	2-6
2.4	Site Support and Management	2-6
2.4.1	Sponsoring Agency Responsibilities	2-6
2.4.2	Operating Agency Responsibilities	2-7
2.5	Site Personnel	2-7
2.5.1	The Site Operator	2-7
2.5.2	The Site Supervisor	2-8
2.6	Technical Support	2-9
2.6.1	Central Analytical Laboratory	2-9
2.6.2	Program Office	2-10
2.6.3	USGS and USEPA Quality Assurance Programs	2-11
2.7	References	2-12
3	NTN Site Operating Procedures	3-1
3.1	General Guidelines	3-1
3.2	Field Procedures	3-1
3.2.1	Preparing for Sample Collection	3-1
3.2.1.1	Check Mailer Contents upon Receipt	3-1
3.2.1.2	Prepare to Service Field Site	3-2
3.2.2	Changing Wet-Side Field Bucket and Checking Equipment	3-2
3.2.2.1	Weekly Sampling Routine	3-3
3.2.2.2	Bulk Sampling	3-6
3.2.3	Maintaining Dry-Side Bucket and Foam Lid Seal	3-6
3.2.3.1	Cleaning Dry-Side Buckets at Field Laboratory	3-6
3.2.3.2	Changing Dry-Side Buckets and Cleaning Foam Lid Seal	3-7
3.2.4	Nonstandard Sample Periods	3-7
3.2.5	Servicing the Belfort Recording Raingage	3-8
3.2.6	Summary of Field Procedures	3-10

3.3	Completing Field Observer Report Form (FORF)	3-10
3.3.1	SITE, Block 1	3-12
3.3.2	OBSERVER, Block 2	3-12
3.3.3	BUCKET ON/OFF, Block 3	3-12
3.3.4	SITE OPERATIONS, Block 4	3-13
3.3.5	SAMPLE CONDITION, Block 5	3-13
3.3.6	BUCKET SAMPLE WEIGHT, Block 6	3-14
	3.3.6.1 Measure Any Leakage	3-14
	3.3.6.2 Weigh the Sample	3-15
3.3.7	PRECIPITATION RECORD, Block 7	3-15
	3.3.7.1 Precipitation Type	3-16
	3.3.7.2 Precipitation Amounts	3-16
	3.3.7.3 Weight Recheck and Collection Efficiency	3-16
	3.3.7.4 Detailed Interpretation of Precipitation and Event Recorder Traces	3-17
	3.3.7.4.1 Chart Features	3-17
	3.3.7.4.2 Event Recorder Transcription	3-19
	3.3.7.4.3 Reading the Raingage Chart	3-20
	3.3.7.4.4 Reporting Daily Precipitation Amounts: Arranging Events to Fit Field Form	3-21
3.3.8	SAMPLE CHEMISTRY, Block 8	3-22
	3.3.8.1 Transferring Liquid from Field Bucket	3-22
	3.3.8.1.1 Decanting into Sample Bottle	3-23
	3.3.8.1.2 Sample Bottle Usage	3-24
	3.3.8.2 General Field Laboratory Analysis	3-24
	3.3.8.2.1 Filling Vials for Field Chemistry Measurements	3-25
	3.3.8.3 Conductance Measurement	3-26
	3.3.8.3.1 Standardize Meter and Cell	3-26
	3.3.8.3.2 Measure Conductance of Distilled Water	3-26
	3.3.8.3.3 Measure Quality Control Check Sample Conductance	3-26
	3.3.8.3.4 Measure Precipitation Sample Conductance	3-27
	3.3.8.3.5 Store Conductance Cell	3-27
	3.3.8.4 pH Measurement	3-27
	3.3.8.4.1 Prepare pH Meter and Electrode for Testing	3-27
	3.3.8.4.2 Calibrate pH Meter	3-28
	3.3.8.4.3 Purge pH Electrode Tip with Distilled Water	3-28
	3.3.8.4.4 Measure Quality Control Check Sample pH	3-29
	3.3.8.4.5 Measure Precipitation Sample pH	3-29
	3.3.8.4.6 Store pH Electrode	3-29
3.3.9	SUPPLIES, Block 9	3-29
3.3.10	REMARKS, Block 10	3-30
3.4	Mailing Instructions	3-30
3.4.1	Field Buckets	3-30
3.4.2	Sample Bottles	3-31
3.4.3	Final Items	3-31
3.5	Recordkeeping at the Site	3-32

4	Preliminary Data Printouts	4-1
4.1	Report Headings	4-1
4.2	CAL Field Printout	4-2
4.3	CAL Preliminary Printout	4-5
4.4	Monthly News and Notes	4-7
4.5	Usage Reminder	4-7
5	Field Site Maintenance	5-1
5.1	Immediate Site Area Maintenance	5-1
	5.1.1 Vegetation Maintenance	5-2
	5.1.2 Obstructions in Wind Field	5-2
5.2	Field Site Equipment Maintenance	5-2
	5.2.1 Aerochem Metrics 301 Precipitation Collector (see also Appendix C)	5-2
	5.2.1.1 Sensor and Motor Box Checks	5-2
	5.2.1.2 Sensor Head Cleaning	5-3
	5.2.1.3 Dry-Side Changes, Lid Seal Cleaning and Replacement	5-3
	5.2.1.4 Winter Operation	5-4
	5.2.2 Belfort B5-780 Recording Raingage (see also Appendix D)	5-5
	5.2.2.1 Winter Operation	5-5
	5.2.2.2 Calibration, Turnover, and Sensitivity Checks	5-6
	5.2.2.2.1 Calibration	5-6
	5.2.2.2.2 Turnover Check	5-7
	5.2.2.2.3 Sensitivity Check	5-7
5.3	Replacement of Field Equipment Components	5-7
5.4	Power Requirements for Field Site Operation	5-7
	5.4.1 110 Volt AC Line Power	5-8
	5.4.2 12 Volt DC Power	5-8
5.5	References	5-9
6	Quality Assurance Programs	6-1
6.1	NTN Site Systems and Performance Survey	6-1
6.2	Blind-Audit Program	6-2
6.3	Intersite Comparison Program	6-3
6.4	Collocated Sampler Program	6-3
6.5	Field Blank Program	6-4
6.6	References	6-4
7	Directory	7-1
7.1	NADP - Central Analytical Laboratory	7-1
7.2	NADP Program Office	7-2
7.3	External Quality Assurance Programs	7-3
7.4	Instrument Manufacturers	7-3

Appendices

A.	National Trends Network Equipment Requirements	A-1
B.	pH and Conductivity Measurement Troubleshooting Guide	B-1
C.	Precipitation Collector Troubleshooting Guide	C-1
D.	Recording Raingage Troubleshooting Guide	D-1

LIST OF FIGURES

Figure 1-1. The atmospheric cycle of air pollutants	1-1
Figure 1-2. National Trends Network (December 31, 1998) ..	1-4
Figure 2-1. A typical NTN site	2-1
Figure 2-2. Ecoregions of the conterminous United States showing Domain, Division, and Province (after Bailey, 1976)	2-3
Figure 2-3. Technical support of NTN sites	2-9
Figure 3-1. Pack the mailer for the field site	3-2
Figure 3-2. Check the sensor temperature	3-3
Figure 3-3. Activate the sensor with water	3-4
Figure 3-4. Put the lid on the bucket	3-4
Figure 3-5. Note comments on the plastic bag	3-5
Figure 3-6. Check that event recorder pen is up	3-5
Figure 3-7. Check the lid seal fit	3-5
Figure 3-8. Mark the pen position	3-8
Figure 3-9. Check the operation of the event recorder	3-9
Figure 3-10. Field Observer Report Form	3-11
Figure 3-11. Block 1	3-12
Figure 3-12. Block 2	3-12
Figure 3-13. Block 3	3-12
Figure 3-14. Block 4	3-13
Figure 3-15. Block 5	3-13
Figure 3-16. Block 6	3-14
Figure 3-17. Measure sample leakage	3-14
Figure 3-18. Upper portion of Block 7	3-15
Figure 3-19. Lower portion of Block 7, weight recheck	3-17
Figure 3-20. Sample raingage chart	3-18
Figure 3-21. Raingage chart section	3-19
Figure 3-22. Transcribe event recorder trace	3-19
Figure 3-23. Chart point 0	3-20
Figure 3-24. Chart point 1	3-20
Figure 3-25. Chart point 2	3-20
Figure 3-26. Chart point 4	3-21
Figure 3-27. Chart point 8	3-21
Figure 3-28. Decant the liquid	3-23
Figure 3-29. Block 8	3-24
Figure 3-30. Rinse and fill four vials	3-25
Figure 3-31. Measure the conductance standard	3-26
Figure 3-32. Remove the soaker bottle	3-27
Figure 3-33. Insert the electrode into the vial	3-28
Figure 3-34. Block 9	3-29
Figure 3-35. Block 10	3-30
Figure 3-36. Make sure the CAL address shows	3-31
Figure 4-1. CAL field printout	4-3

Figure 4-2.	CAL preliminary printout	4-6
Figure 5-1.	An idealized site	5-1
Figure 5-2.	Removing the lid seal	5-4
Figure 5-3.	An idealized DC solar system	5-8

TABLES

Table 3-1.	Chart Precipitation Record	3-22
Table 3-2.	Daily Precipitation Record	3-22
Table 5-5.	Catch Bucket Freezing Temperature	5-6

ACKNOWLEDGMENTS

This manual was revised with guidance from the Network Operations Subcommittee of the National Atmospheric Deposition Program.

Contributors to previous versions include Van C. Bowersox, Jacqueline Peden, Mark Peden, Richard Semonin, Gary J. Stensland, and Scotty R. Dossett of the Illinois State Water Survey; D.L. Sisterson and P.M. Irving of Argonne National Laboratories; and David Bigelow, Nicholas Field, Gary Lear, Susan Smith, and Carol Simmons of the Natural Resource Ecology Laboratory, Colorado State University; and Herbert Volchok (deceased) of the U.S. Department of Energy, Health and Safety Laboratory.

Several Illinois State Water Survey staff contributed their computer, word processing, graphics design, and editing expertise. The authors wish to thank Greg Dzurisin, Joyce Fringer, Linda Hascall, and Eva Kingston for their assistance.

This version was edited by members of the NADP Network Operations Subcommittee. The authors wish to thank the following individuals for their efforts:

Joel Frisch, U.S. Geological Survey Office of Atmospheric Deposition Analysis
Susan Randall Johnson, Minnesota Pollution Control Agency
John Robertson, Past Program Chair
Jane Rothert, Illinois State Water Survey
Jim Trochta, Wisconsin Department of Natural Resources

FOREWORD

This manual is a detailed guide for the operation of a National Atmospheric Deposition Program/ National Trends Network (NTN) wet deposition monitoring station. A description of program history and organization is included so that Site Operators can understand the development of the network.

We would appreciate receiving your comments or suggestions about the content or the style of this manual. Please forward your ideas to:

NADP Program Office
Illinois State Water Survey
2204 Griffith Drive
Champaign, IL 61820-7495
E-mail: nadp@sws.uiuc.edu
NADP Home Page: <http://nadp.sws.uiuc.edu>

The procedures outlined in this manual do not address safety problems associated with the operation of the monitoring station. Each Site Operator and Supervisor are responsible for establishing appropriate safety and health practices.

SUMMARY OF REVISIONS

This manual is the third revision of the original 1978 *Field Observer Instruction Manual* by Richard Semonin and Herbert Volchock. Several procedural changes have occurred within the program since the original manual was printed. The table below lists additions and changes in NTN Site Operation protocols since 1994. For information regarding procedural changes prior to 1994, please contact the Program Office (see inside front cover for contact information).

<i>Revisions</i>	<i>Date</i>
Revision of Section 7 with updated contact information for CAL, Program Office, and Quality Assurance personnel.	Jan 06
Addenda were added to address procedural changes that occurred when field chemistry (pH and conductance) measurements were discontinued effective Jan 05. Addenda include: <ul style="list-style-type: none">• page 3-11: new NTN Field Observer Report Form (FORF) replaces the FORF in Figure 3-10 on the original page 3-11• page 3-25a: replaces Sections 3.3.8.2 (pages 3-24 to 3-26), 3.3.8.3 (pages 3-26 to 3-27), and 3.3.8.4 (pages 3-27 to 3-29)• page 25b: describes protocol for removing an aliquot for field chemistry measurements (only for sites that opt to continue these measurments with support from outside the NADP)• page 3-31: describes new procedures for attaching bar code labels to the FORF and sample bottle bag• page A-3: lists information about supplies for field chemistry measurements (only for sites that opt to continue these measurments with support from outside the NADP)	Dec 04
Revision of the text in sections 2.3.1 (page 2-5), 3.2.2 (page 3-3), and 3.2.4 (pages 3-7 and 3-8) to reflect a change of the data validation criteria. The NADP committees decided to use short-duration samples in calculating annual and seasonal averages and other statistics. Previously, sampling periods shorter than 6 days or longer than 8 days and 2 hours (194 hours) were considered invalid for use in these calculations. The decision was to eliminate the 6-day limit but keep the 8-day and 2-hour limit. The text on these pages has been amended to reflect these changes.	Jul 04

<i>Revisions</i>	<i>Date</i>
Revisions of Section 7, with updated contact information for CAL, Program Office, and Quality Assurance personnel, and Appendix A, with an additional precipitation collector manufacturer and new pH and conductance meter and balance models.	Aug 03
Major revision of all sections of the manual with an emphasis on updating information, language, graphics, and on producing an all-electronic document. Specific changes include: <ul style="list-style-type: none"> • Revision of text to accommodate the title change of the network from the National Atmospheric Deposition Program to the National Trends Network (NTN). • Revision of text to eliminate references to dry-side sampling, which was discontinued in Oct 98. • Revision of Field Observer Report Form (FORF). • Inclusion of graphics and photos in Sections 1, 2, and 3. • Revision of Section 3 to describe the standard procedures for collecting a sample, servicing the recording raingage, completing the FORF, performing field chemistry measurements, mailing the sample and FORF, and maintaining records. • Modification of Section 5 to add special procedures throughout text. • Revision of Section 6 to add information dealing with a new U.S. Geological Survey Field Blank program. • Revision and expansion of Section 7. 	Jul 99
The network changed its sample handling and shipping protocol. A snap-on lid is used to retrieve the sample from the field site. Any liquid in the field bucket is decanted into a 1-liter (L) high-density polyethylene bottle for shipment to the Central Analytical Laboratory. Instead of using a syringe to withdraw a 20-mL aliquot for field chemistry, the vials used are filled from the 1-L bottle. Any sample volume in excess of ~900 grams is discarded. Since the entire sample is no longer available, the evaluation of contaminants in the sample and the field sample weight shifts from the CAL to the site. The sample is no longer in contact with the “O-ring” gasket found in the old style hammer-on lids. Section 3 of the manual was edited substantially to accommodate new procedures.	Jan 94

1 Introduction

1.1 Atmospheric Deposition: Why Be Concerned?

Every year the National Atmospheric Deposition Program (NADP) fulfills thousands of requests for data, maps, and other information through its World-Wide-Web site. These requests come from scientists and policy-makers and from students and other people interested in using NADP data to address important questions about the health of our atmosphere. The NADP is now in its third decade and has a continuous record of more than 20 years of precipitation chemistry data at some sites. The length and quality of the NADP data record are due to the steadfast efforts of NADP Site Operators who have spent several hundred thousand hours collecting and measuring samples. Why do we keep such diligent vigil over what's in our precipitation? The answer lies in our need to monitor how human activities and the forces of nature affect our air and precipitation quality, i.e., the health of our atmosphere. The information we gain will equip us to make more responsible decisions about how to preserve and improve our air quality and how to manage our agricultural, forest, aquatic, cultural, and energy resources.

As rain or snow forms and falls, it scavenges or removes particles and gases from the air. Precipitation deposits these substances on the earth's surface. Differences in the chemical makeup of precipitation from one sampling site to another reflect differences in the form or quantity of pollutants scavenged from the atmosphere at these sites. Changes in precipitation chemistry at a site occur from week to week and from year to year. Monitoring precipitation chemistry over space and time helps us describe the chemical climate in a region and throughout the country. Many factors affect the chemical climate: emissions of pollutants to the atmosphere, how these pollutants are mixed or dispersed in the air, how they are transported by the wind, how they chemically change or transform during transport, and finally how they are scavenged by precipitation or removed as dry deposition (Figure 1-1). This description makes it apparent that the interplay of meteorology and atmospheric chemistry affect precipitation chemistry in defining our chemical climate.

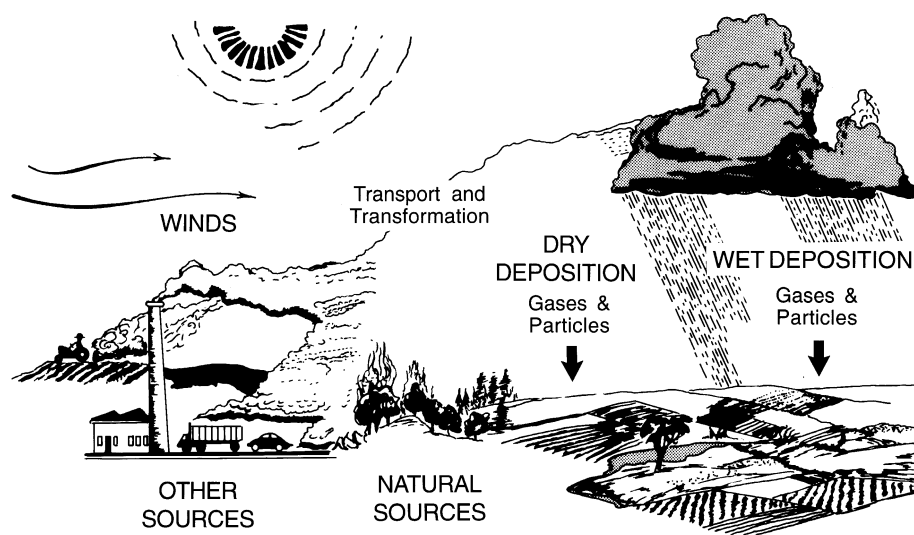

Figure 1-1. The atmospheric cycle of air pollutants.

Figure 1-1 depicts how pollutants cycle through the atmosphere. Some pollutants remain relatively unchanged during this cycle. For example, soil particles may be transported without change from a source area, such as a field, to a sink, such as a forest downwind of the field. During this source-to-sink cycle, other pollutants undergo physical and chemical changes. For example, sulfur dioxide is a gas when emitted from its point source, a tall smokestack. Before being scavenged by precipitation or removed as dry deposition, sulfur dioxide may be transformed into tiny sulfuric acid droplets or into ammonium bisulfate particles. Whether pollutants are merely relocated or are chemically transformed during this atmospheric cycle, it is now recognized that atmospheric deposition significantly affects the supply of both essential and potentially injurious compounds available to natural systems. It also affects the weathering and corrosion rates of building materials and structures, our cultural resources.

Atmospheric deposition affects the nutrient status, growth, and development of plants on land and in surface waters. It may benefit agricultural crops by adding nutrients that promote growth. Plant growth also may be stimulated when the acids in precipitation accelerate the weathering of soils, making minerals more readily available. Growth stimulation in certain unmanaged forests, however, may make the trees less hardy and more vulnerable to the stresses of cold weather and disease. Adding nutrients to surface waters may boost algal production, and when these algae die, they sometimes deplete the oxygen supply below levels that support fish. The health and reproductive capacity of fish can also be influenced by the atmospheric deposition of acids and other trace constituents. Where precipitation is acidic, it can speed the corrosion of exposed metals and the weathering of unprotected stone building surfaces and statues. In these examples, atmospheric deposition has an influence on biological and geological systems, playing an important role in the biogeochemical cycle, and it modifies natural weathering and corrosion processes.

Because precipitation is an efficient scavenger of the particles and gases dispersed in the atmosphere, precipitation chemistry is a good indicator of the pollutants in our air. Changes in the chemical composition of precipitation reflect changes in atmospheric composition. Atmospheric deposition plays an important role in the biogeochemical cycle and in the weathering and corrosion of exposed building surfaces and statues. Pollutant emissions are expected to change because of legislated reductions and inadvertent changes in natural sources. There is a continuing need to make careful measurements of precipitation chemistry and thus monitor the health of our atmosphere.

1.2 NADP Monitoring: Program History and Objectives

In October 1977, the North Central Region of the State Agricultural Experiment Stations (SAES) established Project NC-141, entitled "Chemical Changes in Atmospheric Deposition and Effects on Agricultural and Forested Land and Surface Waters in the United States." Interest in Project NC-141 grew out of concern over reports of increasing acidity of rain and snow in the eastern United States and from the recognition that human activities had greatly increased the emissions and deposition of atmospheric pollutants. An expert panel meeting at the National Academy of Sciences in 1976 recommended that a nationwide network be installed to measure the spatial and temporal trends in atmospheric deposition. Scientists could use data from this network to examine the connection between emissions and precipitation chemistry and between precipitation chemistry and potential impacts on agriculture, forests, rangelands, streams, and lakes. Among the first accomplishments

of Project NC-141 was to begin installing a network of sampling sites. The first sites in the NADP monitoring network began operations in the summer of 1978, and by the end of that year 22 sites had joined the network.

All four SAES regions endorsed NADP as Interregional Project IR-7 in 1982. This endorsement accompanied the growth of the network to 106 sites in 41 states plus a site in American Samoa and three sites installed alongside Canadian network sites in the provinces of Alberta, Ontario, and Nova Scotia. A decade later, the SAES reclassified IR-7 as National Research Support Project NRSP-3, entitled "The National Atmospheric Deposition Program—A Long-term Monitoring Program in Support of Research on Effects of Atmospheric Chemical Deposition." The objective of Project NRSP-3 is to provide a national framework for collecting and disseminating quality-assured atmospheric deposition data:

1. To characterize geographic patterns and temporal trends in biologically important chemical deposition.
2. To support research activities related to (a) the productivity of managed and natural systems; (b) the chemistry of surface and ground waters, including estuaries; (c) the health of domestic animals, wildlife, and fish; (d) human health; (e) the effects of atmospheric deposition on visibility and materials; and (f) discerning source-receptor relationships.

In October 1981, the U.S. Congress established the National Acid Precipitation Assessment Program (NAPAP) to increase our understanding of the causes and effects of acid precipitation. Federal agencies worked together in this comprehensive ten-year program to conduct research, monitoring, and assessment activities intended to develop a firm scientific basis for reducing the effects of acid precipitation. This program sought to operate a long-term, high-quality National Trends Network (NTN) to detect and measure acid precipitation. Under the NAPAP design, the U.S. Geological Survey (USGS) was charged with leading network development and operation. The NADP siting criteria, operating equipment, procedures, and analytical laboratory were adopted by NTN, and the two networks merged with the designation NADP/NTN. Recognizing that the network needed more sites to have representative data on precipitation chemistry in all ecoregions, the federal agencies supported the installation of new sites, particularly in the western United States (Robertson and Wilson, 1985). By the end of 1985, the network had grown to nearly 190 sites. In 1998, the network designation, NADP/NTN, was shortened to NTN.

1.3 NADP Status: Current and Future

Figure 1-2 shows the active sites in the NTN as of December 31, 1998. The network operates in 46 states, has 200 active sites, and extends from Puerto Rico and the Virgin Islands in the east to Alaska in the west. Two of the network sites are paired collocated sites, operating two collectors and precipitation gages. Collocated sampling is one component of the network quality assurance program. Another is collecting samples at sites where other networks collect samples. For example, NTN operates two network-comparison sites alongside federal Canadian sites in the Canadian Air and Precipitation Monitoring Network (CAPMoN): one site in Quebec Province, Canada, the other in central Pennsylvania. Collocated and network-comparison sampling are quality assurance activities designed to evaluate the overall precision and comparability, respectively, of network data.

NAPAP, the ten-year program responsible for the design and operation of the NTN, continues under the most recent amendments to the federal Clean Air Act. NTN data are necessary to evaluate the status and effectiveness of the acid deposition control program implemented under these amendments. The Act seeks to reduce the adverse effects of acid deposition through reductions in annual emissions of sulfur dioxide and nitrogen oxides. The first round of sulfur dioxide emission reductions occurred on January 1, 1995. According to the Act, a second round of reductions must occur before January 1, 2000, lowering the total annual sulfur dioxide emissions to 10 million tons below 1980 levels. With nearly 200 sites measuring precipitation chemistry in the major ecoregions of the United States, the NTN is well-positioned to provide the data necessary to assess the location and magnitude of changes in precipitation chemistry resulting from these emissions reductions.

Complementing the NTN is a research network, the Atmospheric Integrated Research Monitoring Network (AIRMoN), that focuses on detecting how sources and meteorology affect precipitation chemistry on a day-to-day basis. AIRMoN joined NADP in October 1992. Data from this network are combined with results from atmospheric models that track air movements. Together, the AIRMoN measurements and air parcel trajectories are used to investigate the nature of the relationship between sources and precipitation chemistry. AIRMoN also evaluates new sample collection methods and preservation methods designed to arrest the biodegradation of ammonium, an important nutrient, and losses of free acidity. As of December 31, 1998, there are ten AIRMoN sites, all located in the eastern United States.

Another network, the Mercury Deposition Network (MDN), with 38 sites as of December 31, 1998, joined NADP in January 1996. MDN reports the total mercury concentrations in all samples and methyl mercury concentrations in some samples. Nearly 40 states have advisories against consuming fish from certain lakes because of high mercury concentrations in the fish tissues. MDN data enable researchers to examine the importance of the atmospheric transport and deposition of mercury from distant sources as a cause of this problem.

With the addition of AIRMoN and MDN, NADP now operates three precipitation chemistry networks. Data from these networks are used to address a number of important contemporary issues. For example, NADP data are being used:

- To assess the effect of sulfur dioxide emissions reductions on sulfate in precipitation.
- To update the recommendations for sulfur fertilizer applications in light of the lower sulfur amounts deposited by precipitation in many areas of the country.
- To estimate the amount and importance of atmospheric inorganic nitrogen deposited to inland and coastal waters in which nutrient enrichment degrades the water quality.
- To explore the causes of the downward trend in base cation concentrations in precipitation and the effect this may have on the fertility of some acidic forest soils.
- To continue to monitor how acidic lakes and forests respond to the changing chemistry of precipitation.
- To examine the relationship between pollutant sources, air quality, and precipitation quality.
- To determine the deposition rate of mercury to lakes and streams and evaluate the relative importance of atmospheric deposition and other sources of mercury in causing high mercury levels in fish.

Support for NADP comes from a diverse group of sponsors and participants, ranging from landowners that provide a site location to federal agencies that fund dozens of sites. These include a high school, the U.S. Military Academy, the Kennedy Space Center, Native American tribal organizations, private companies, city governments, state agencies, universities, Forest Experiment Stations, State Agricultural Experiment Stations, national laboratories, agencies of the Canadian government, the U.S. Geological Survey, the National Oceanic and Atmospheric Administration, the U.S. Environmental Protection Agency, the National Park Service, the U.S. Forest Service, the Bureau of Land Management, the U.S. Fish & Wildlife Service, the Tennessee Valley Authority, and the Cooperative State Research, Education, and Extension Service.

The dedication of NADP sponsors and Site Operators continues to make NADP one of the most successful cooperative programs in the United States. Here's what scientists have said in review of the NADP, "The monitoring program is perhaps the most significant long-term, continuous, and comprehensive sampling and analysis program to be undertaken in the environmental sciences" (Jansen et al., 1988). Extending this record so that future peer reviewers can say no less is the challenge of every person involved with the NADP today.

1.4 References

Jansen, J., K. Aspila, M. Hoffman, G. Ohlert, and J. Winchester. 1988. *Session Summary Report. NAPAP Task Group IV, Wet Deposition Monitoring Peer Review*. National Acid Precipitation Assessment Program, 722 Jackson Place, NW, Washington, D.C.

Robertson, J., and J. Wilson. 1985. *Design of the National Trends Network for Monitoring the Chemistry of Atmospheric Precipitation*. U.S. Geological Survey, Circular 964, Alexandria, VA.

2 National Trends Network Monitoring Program

2.1 NTN Monitoring Strategy

In establishing the NTN, sponsors and participants have sought to ensure long-term commitment and uniformity of siting criteria, sampling protocols, analytical methods, and data validation procedures. Complemented by long-term operations, this uniformity is essential to obtain data on how the chemical climate in the nation's ecoregions is changing over seasons, years, and decades. This uniformity helps to ensure that data are geographically representative and comparable from site to site. To this end, NTN participation requires use of prescribed field instruments to collect and measure precipitation (see Figure 2-1 and Appendix A). Sites also must conform to fixed site selection and installation criteria and must follow identical procedures for collecting, handling, and measuring samples. Although the amount and type of data may vary, certain minimum data must accompany every sample.



Figure 2-1. A typical NTN site.

Every NTN sample is sent to the Central Analytical Laboratory (CAL), operated by the Illinois State Water Survey in Champaign, Illinois. The CAL provides site support, chemical analysis, and data validation services for the NTN. As overall indicators of precipitation quality, the CAL measures pH and conductivity, which are also measured at field sites. The CAL also analyzes samples for the following constituents: sulfate (SO_4^{2-}), chloride (Cl^-), nitrate (NO_3^-), ammonium (NH_4^+), orthophosphate (PO_4^{3-}), sodium (Na^+), potassium (K^+), calcium (Ca^{2+}), and magnesium (Mg^{2+}). These ions characterize the inorganic chemistry of precipitation. For example, NO_3^- , NH_4^+ , and PO_4^{3-} are the principal inorganic nutrients in precipitation. Hydrogen ion (H^+ , measured as pH), SO_4^{2-} , and NO_3^- are the well-known constituents of "acid rain"; and Ca^{2+} , Mg^{2+} , and K^+ are important base cations in precipitation. Field and laboratory data are verified and screened at the CAL, following a standard set of data validation procedures to ensure accuracy and representativeness of NTN data.

Finally, the U.S. Geological Survey (USGS) and U.S. Environmental Protection Agency (USEPA) administer external quality assurance programs that continuously review and evaluate field sites, their operations, and those of the CAL.

2.2 Site Selection

NTN sites were selected to provide *regionally representative* data for use in characterizing the geographic patterns and temporal trends in atmospheric chemical deposition. To avoid unrepresentative influences from nearby sources, NTN sites were installed predominantly away from urban areas and point sources of pollution, such as coal-fired power plants or other industrial operations. A

regionally representative site typifies an area or region, which is distinguished from other regions by vegetation, soil types, climate, or other properties. An overarching consideration in the NTN design (Robertson and Wilson, 1985) was to measure atmospheric deposition in every ecologically similar region, i.e., an ecoregion, as defined by Bailey (1978). The number of sites in the ecoregions was set in proportion to the ecoregion areas, shown in Figure 2-2. This basic distribution of sites was augmented by other important considerations, such as

- location of atmospheric pollutant sources.
- amount and frequency of precipitation.
- location of rapid changes (i.e., sharp spatial gradients) in atmospheric deposition.
- measurement of pollutant fluxes across national borders.
- chemical deposition to sensitive agricultural, aquatic, and forested areas.

Finally, where it was possible to support deposition effects research, sites were located where biological, limnological, geological, atmospheric chemistry, or related studies were already underway.

New sites continue to be added to the NTN to support research on emerging topics such as biogeochemical cycling in watersheds, excess nutrients in estuarine waters, and other problems. Protocols for establishing NTN monitoring sites are contained in the *NADP/NTN Instruction Manual: Site Selection and Installation* (NADP, 1984), which is available from the NADP Program Office (see Section 7.2 for contact information).

2.3 Field Site Operations

Atmospheric deposition occurs as wet and dry deposition. Wet deposition includes the mixture of dissolved gases and particles and undissolved particles that occur in liquid or frozen precipitation (i.e., rain, snow, sleet, and hail). These substances are present in precipitation at part per million, or lower, levels. These very dilute concentrations require that extreme care be exercised to avoid introducing contamination when collecting, handling, and measuring samples. All sample containers are cleaned and provided only by the CAL. To minimize contamination, the CAL follows rigorous cleaning procedures using ultra-pure deionized water. Another source of contamination of wet deposition samples is dry deposition, which occurs continuously and includes gases and particles transferred to the earth's surface by physical processes other than precipitation. Gravitational settling, wind-driven impaction, absorption of airborne pollutants, dew, frost, and fog are all dry deposition mechanisms. A wet-deposition-only sample is a wet deposition sample collected only during precipitation so that significant dry deposition is excluded. Collection of uncontaminated wet-deposition-only samples is the primary goal of NTN field site operations.

The NTN requires that every site use two commercially available instruments for the collection and measurement of precipitation: the Aerochem Metrics 301 precipitation collector (ACM) and the Belfort B5-780 recording raingage, which are pictured in Figure 2-1. The electrically powered ACM collector automatically collects precipitation samples for chemical analysis, and the Belfort gage mechanically measures and records the amount of precipitation. Appendix A lists the field site equipment requirements.

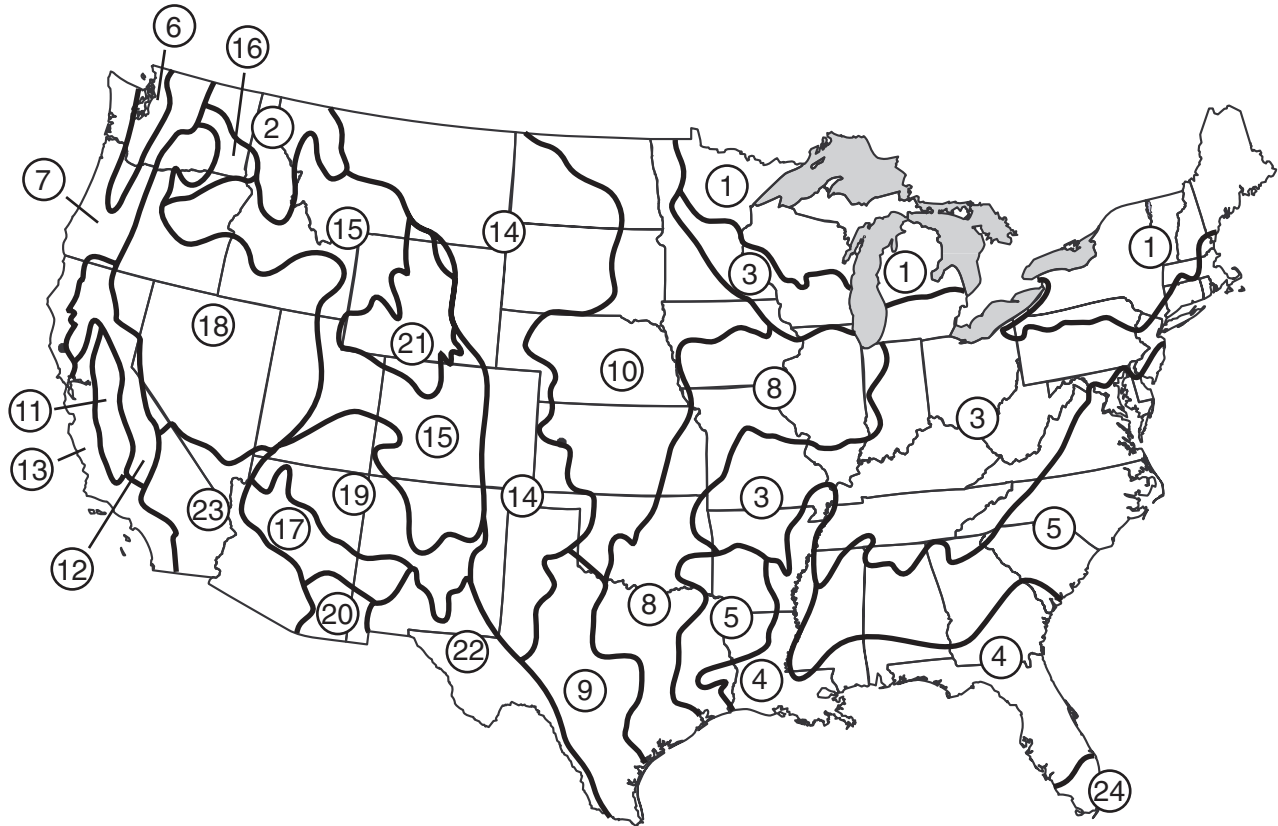

- HUMID TEMPERATE**
- Warm Continental**
1 Laurentian Mixed Forest
2 Columbia Forest
- Hot Continental**
3 Eastern Deciduous Forest
- Subtropical**
4 Outer Coastal Plain Forest
5 Southeastern Mixed Forest
- Marine**
6 Willamette-Puget Forest
7 Pacific Forest
- Prairie**
8 Prairie Parkland
9 Prairie Brushland
10 Tall-Grass Prairie
- Mediterranean**
11 California Grassland
12 Sierran Forest
13 California Chaparral

- DRY**
- Steppe**
14 Great Plains-Shortgrass Prairie
15 Rocky Mountain Forest
16 Palouse Grassland
17 Upper Gila Mountains Forest
18 Intermountain Sagebrush
19 Colorado Plateau
20 Mexican Highland Scrub Steppe
21 Wyoming Basin
- Desert**
22 Chihuahuan Desert
23 American Desert

- HUMID TROPICAL**
- Savanna**
24 Everglades

HUMID TEMPERATE = Domain
Warm Continental = Division
1 Laurentian Mixed Forest = Province

Figure 2-2. Ecoregions of the conterminous United States showing Domain, Division, and Province (after Bailey, 1976).

The ACM collector has side-by-side 3.5-gallon linear polyethylene (LPE) buckets, one labeled *WET* and the other labeled *DRY* on the instrument base. (Elsewhere in this manual, the terms wet-side bucket or wet side of the collector are used to refer to the side of the ACM collector labeled *WET*; a similar convention applies to the side labeled *DRY*.) Between precipitation events a motor-driven lid covers the wet-side bucket. The underside of this lid has a compressible pad (called a lid seal) that seals the wet-side bucket from exposure to the atmosphere. When precipitation occurs, a sensor activates the motor, which moves the lid from the wet-side bucket to the dry-side bucket. While precipitation accumulates in the wet-side bucket, the dry-side bucket protects the lid seal from contamination by splash and dry deposition. The sensor is heated so that when precipitation ends, it dries and activates the motor to once again cover the wet-side bucket. For NTN, the purpose of the wet-side bucket is to collect wet-deposition-only samples. The purpose of the lid seal is to protect these wet-deposition-only samples from evaporation and contamination by dry deposition. The dry-side bucket serves two purposes: (1) to protect the lid seal from contamination during precipitation, and (2) to collect precipitation that is missed by the wet-side bucket so that this missed precipitation can be reported. Because of malfunctions in the ACM sensor, motor, power supply, etc., not all samples are wet-deposition-only. Section 2.3.2 defines the three NTN sample types for which the definitions are based on the exposure of the wet-side bucket to atmospheric (wet and dry) deposition.

The Belfort gage is a spring-scale device with a wind-up or battery-powered clock that spins a recording chart drum. The Belfort catch bucket is always open to receive precipitation. Precipitation that accumulates in the catch bucket compresses the spring scale. Through a mechanical linkage, the spring scale deflects a pen in proportion to the precipitation amount. This pen records the precipitation amount on the chart drum. Since the chart drum makes one complete revolution every 8 days, it records the amount and time of precipitation. In addition, the gage is equipped with an event recorder that records the duration of the opening of the wet-side bucket. The purpose of the Belfort gage is to measure precipitation with a device that is independent of the automated ACM collector and is specifically designed to record precipitation amounts. The purpose of the event recorder is to record the opening and closing of the wet-side bucket in a way that can be readily compared with the occurrence of precipitation. This comparison is an important way to verify that the sample in the wet-side bucket is a wet-deposition-only sample.

Every Tuesday Morning (NADP,1994), the NTN training video available from the CAL (see Section 7.1 for contact information), describes the procedures that every Site Operator is expected to follow (see Section 2.5.1 for responsibilities). Every Tuesday morning, the Site Operator travels to the field site, notes any changes or unusual circumstances in the immediate area, collects the bucket from the wet side of the ACM collector and replaces it with a CAL-cleaned bucket, changes the chart in the Belfort gage, and performs checks to ensure the field equipment is operating properly. The Site Operator then transports the bucket and gage chart to the field lab where the bucket is weighed and the sample it contains (up to 1 liter) is transferred to a sample bottle. If the sample weighs 70 grams or more, a portion is poured from the sample bottle and used for field chemistry measurements. The remaining sample is sent to the CAL for chemical analysis. All data and information for the sample are recorded on the NTN Field Observer Report Form (FORF) sent to the CAL along with the sample bottle, gage chart, and used bucket.

2.3.1 The Standard Sampling Period

The sampling period is the time interval that begins when the bucket is installed in the wet side of the ACM collector and ends when it is removed. Below are several descriptions of standard sampling periods:

- Samples accumulate for 1 week, Tuesday to Tuesday.
- Wet-side buckets are removed and replaced at approximately 9 a.m. (0900 hours) local time each Tuesday. If it is raining or snowing at collection time, buckets are changed after precipitation stops or as dictated by the Site Operator's travel schedule. To ensure standardization among sites, samples should be from 6 to 8 days in duration. To be included in the NTN data and statistical summaries, sampling periods must not exceed 194 hours, i.e., 8 days and 2 hours.
- Wet-side buckets are replaced weekly, measured, and sent to the CAL even when no precipitation was collected. Buckets containing no precipitation may be used for "field blanks," which are checked for the same ions as precipitation and are used to assess possible contamination. "Field blanks" are part of the NTN quality assurance program and are described in Section 6.5.

Every 8 weeks the dry-side bucket is replaced with a bucket cleaned on site. The lid seal, too, is cleaned on this same schedule. See Section 3.2.3 for a detailed description of these procedures.

2.3.2 Sample Types

2.3.2.1 Wet-Deposition-Only Sample

A wet-deposition-only sample is a wet deposition sample collected only during precipitation so that significant dry deposition is excluded. Collection of uncontaminated wet-deposition-only samples is the highest priority of NTN field site operations. During normal operation of the ACM collector, the wet-side bucket is uncovered when precipitation is occurring and is covered when precipitation is not occurring, i.e., during dry weather. Short periods of exposure to dry weather may occur, however, while the sensor is drying after precipitation ends. To accommodate this limitation in the ACM sensor performance, the NTN applies an operational definition of a wet-deposition-only sample as a sample that has been exposed to dry weather for 6 hours or less during the 1-week sampling period. Another limitation of the ACM sensor is its insensitivity to drizzle and light snow, which causes the precipitation amount in the bucket to be lower than the amount in the Belfort gage. Note that the operational definition is based on the sample's limited exposure to dry deposition, not on the agreement between precipitation depths in the wet-side bucket and in the Belfort gage (referred to as "collection efficiency" and discussed in Section 3.3.7.3).

2.3.2.2 Bulk Sample

A wet-side bucket exposed continuously to the atmosphere during the entire sampling period is defined as a bulk sample. A bulk sample is collected when the ACM lid is positioned and secured over the dry-side bucket by the Site Operator. The Site Operator chooses this protocol because the ACM collector has failed the tests to open and close normally during precipitation and dry weather, respectively. An ACM collector malfunction or power problem is the most common cause of the problem. While collecting a wet-deposition-only sample is the highest priority for NTN field operations, collecting a bulk sample is preferable to collecting no sample or an undefined sample (see

Section 2.3.2.3). That's because exposure of bulk samples to the atmosphere is well-defined. Bulk samples are flagged in the NTN database so that data users can distinguish them from wet-deposition-only samples.

2.3.2.3 Undefined Sample

Any sample that is not a wet-deposition-only or bulk sample is an undefined sample. An undefined sample occurs when the ACM collector malfunctions or fails and the wet-side bucket is open during dry weather for more than 6 hours. Typically, this equipment problem occurs during a sampling period, making it difficult to ascertain exactly when abnormal exposure of the wet-side bucket began. One example is when the ACM sensor heater stops working and the sensor dries only under ambient conditions. If a nighttime rain shower occurs during this scenario, the wet-side bucket may remain open until the sensor is heated the next day by the sun. Another example is when a switch fails and the ACM lid cycles continuously between the buckets. In both examples, detailed documentation would be needed to communicate the conditions under which the wet-side buckets were exposed to wet and dry deposition. Since this documentation is not available, the NTN defines these samples as undefined samples and flags the data as invalid.

2.4 Site Support and Management

Section 1.2 describes the origin and evolution of NADP, which is SAES National Research Support Project-3, a long-term monitoring program in support of research on the effects of atmospheric chemical deposition. Project NRSP-3 forms the basis for agencies of the federal government, state and local governments, and other public and private research organizations to cooperate in pursuit of commonly held goals and objectives. It also provides the organizational framework for governing the NTN. NTN methods and procedures are set by the NADP Technical Committee. All site Sponsoring and Operating Agencies are representatives, as are other interested persons, including scientists, technicians, policy-makers, and managers who attend the annual meeting. Interested persons are encouraged to become active in the Technical Committee and in one or more of its three subcommittees, the Network Operations Subcommittee, the Data Management and Analysis Subcommittee, and the Environmental Effects Subcommittee. The NADP Web page (see Section 7 for the address) contains up-to-date information on past and upcoming meetings.

Every NTN site has a Sponsoring Agency and an Operating Agency. For some sites the Sponsoring and Operating Agencies may be the same. These Agencies are generally responsible for ensuring that the equipment, facilities, materials, resources, and people are available to run the site and for paying for CAL and NADP Program Office services. All sites are expected to have the required equipment and to follow the NTN standard operating procedures described in Section 3.

2.4.1 Sponsoring Agency Responsibilities

Describing the nation's chemical climate requires a high-quality data set. Success in meeting this goal requires the stable long-term commitment of NTN's Sponsoring Agencies. Sponsoring Agencies support one or more sites and are members of the NADP Technical Committee. Each site must have a Sponsoring Agency in order to participate in the NTN.

Sponsoring Agency responsibilities include:

- Providing funds to pay for NTN participation, which includes the services provided by the CAL and NADP Program Office.
- Partnering with an Operating Agency (see Section 2.4.2) to ensure a site has the material resources and people to maintain and operate the site in compliance with NTN requirements and standard operating procedures.
- Participation in the NADP Technical Committee and Subcommittees.

2.4.2 Operating Agency Responsibilities

Each NTN site has an Operating Agency that ensures the site is equipped properly, the equipment is installed in compliance with network siting criteria, and that standard site operational procedures are followed. Operating Agencies and Sponsoring Agencies cooperate to provide the resources necessary to fulfill these obligations. Operating Agencies designate a Site Supervisor (see Section 2.5.2) who oversees site operations and assists in solving operational or other problems. Operating Agencies are members of the NADP Technical Committee.

Operating Agency responsibilities include:

- Providing and maintaining an ACM collector and Belfort gage equipped with an event recorder to collect and measure precipitation at the field site and a weighing scale, pH meter, and conductivity meter/cell to measure the sample weight, pH, and conductivity in the field laboratory (see Appendix A).
- Arranging for the resources to install, operate, and maintain a field site and field laboratory, including (1) land-use (e.g., lease) agreements, (2) site security, (3) travel to the site, (4) compliance with site installation criteria, (5) adequate DC (solar/battery) or AC power for the ACM collector, (6) repair/replacement of pH meter and conductivity meter/cell as needed, (7) initial training of the Site Operator, and (8) the cost of sending samples to the CAL.
- Providing a Site Operator (see Section 2.5.1) who operates and maintains the site and helping the Site Operator to solve operational or siting problems when they arise.
- Participating in the NADP Technical Committee and Subcommittees.

2.5 Site Personnel

Each site has a designated Site Operator and Site Supervisor who perform the routine and occasional special tasks necessary to operate the site in accordance with standard NTN procedures and criteria.

2.5.1 The Site Operator

The Site Operator has primary responsibility for monitoring equipment operation and maintenance, physical maintenance of the site, weekly collection and measurement of samples, sample documentation, and submission of samples and documentation to the CAL. One or more observers may assist the Site Operator in these responsibilities. Excluding travel to the site, Site Operators

generally spend about 2 hours performing their weekly duties. Through their diligence to these duties, Site Operators are largely responsible for determining the quality of NTN data. Their cooperation and dedication continue to make NTN one of the most successful environmental monitoring programs anywhere.

Site Operator duties include:

- Travel to the field site and inspect the site and equipment every Tuesday.
- Collect the wet-side bucket from the ACM collector and the Belfort gage chart.
- Install a new Belfort gage chart and clean ACM collector bucket for the next sample.
- Perform routine equipment maintenance or repairs as needed or prescribed.
- Transport the bucket and Belfort gage chart to the field laboratory.
- Weigh the bucket and transfer the sample it contains to a sample bottle.
- For samples of 70 grams or more, remove a portion from the sample bottle to measure sample pH and conductivity.
- Read and interpret the event recorder and precipitation records on the Belfort gage chart.
- Record the precipitation data, field chemistry data, and all other sample data and information on the NTN FORF.
- Ship the sample bottle, used bucket, completed FORF, and Belfort gage chart to the CAL within 48 hours of sample collection.
- Perform occasional special maintenance (see Section 5) or quality assurance tasks in cooperation with the CAL or other agencies.
- Contact the CAL with any questions about equipment or procedures.

Section 3 describes the Site Operator procedures in detail. Another resource is the training video, *Every Tuesday Morning*, which demonstrates the procedures that Site Operators follow. All Site Operators should have a copy of this video. See Section 7.1 for information on where to get a copy of the video. In addition, the NADP Program Office sponsors an annual Site Operator Training Course, and Site Operators are encouraged to attend. See Section 7.2 for contact information about the next course.

2.5.2 The Site Supervisor

The Site Supervisor is responsible for overseeing site operations and for ensuring that protocols are followed. A Site Supervisor may be on site or remote; however, the tasks remain essentially the same.

A Site Supervisor:

- Ensures that the Site Operator follows standard NTN site operational procedures.
- Reviews the site data, especially the reports and summaries issued by the CAL and NADP Program Office, to look for anomalies and possible problems.
- Assists the Site Operator in troubleshooting operational or procedural problems and works with the Sponsoring or Operating Agencies to arrange for resources needed to correct these problems.

2.6 Technical Support

Sites receive technical support from four organizations: (1) the NTN Central Analytical Laboratory (CAL), (2) the NADP Program Office, (3) the USGS Branch of Quality Systems, and (4) a USEPA contractor, Advanced Technology Systems (ATS), Incorporated, which conducts site systems and performance surveys. Technical support from these organizations covers a broad range of topics, including guidance in installing sites, day-to-day help in troubleshooting equipment malfunctions, assistance with pH and conductivity measurement problems, and conducting site performance evaluations. Figure 2-3 illustrates the relationship between these organizations and NTN sites.

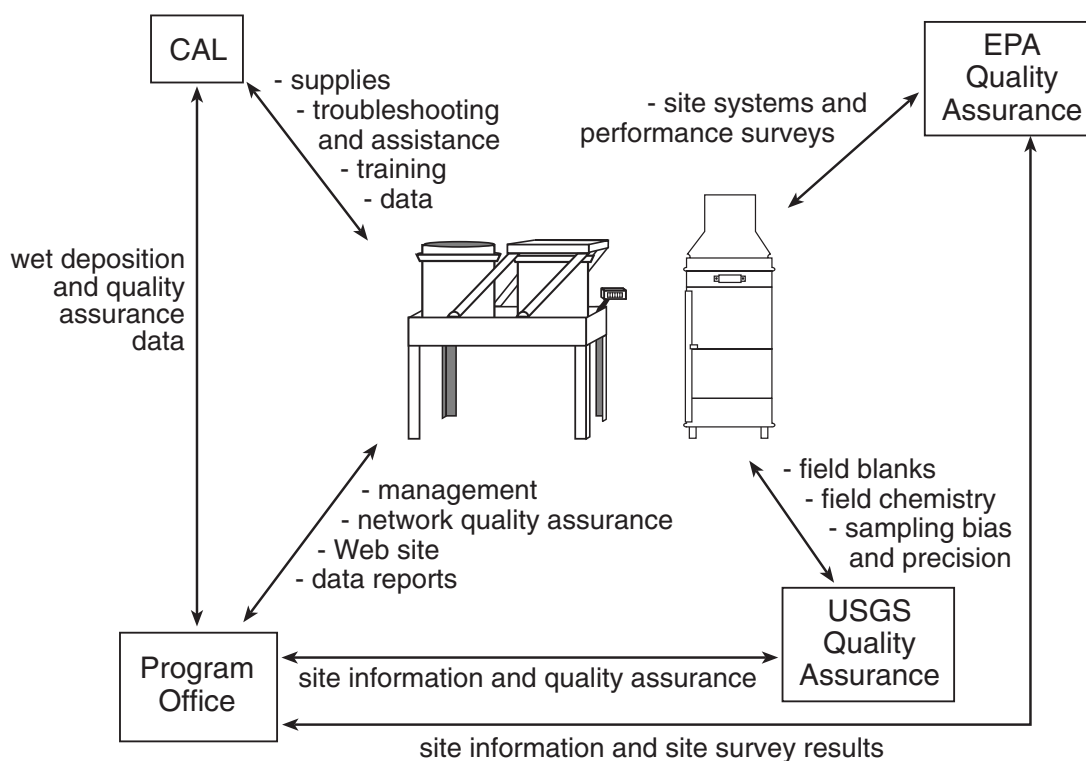

Figure 2-3. Technical support of NTN sites.

Section 7 lists contact information for these organizations.

2.6.1 Central Analytical Laboratory

All NTN samples are sent to the CAL at the Illinois State Water Survey (ISWS). The CAL provides site support, chemical analysis, and data reporting and validation services. This includes providing certain supplies needed for site operations, providing information on site operational problems and procedures, providing chemical analyses of samples, and verifying, screening, and reporting the data.

On receipt of a sample, the CAL replaces the used bucket, lid, and sample bottle with clean ones and returns these supplies to the site. Other expendable supplies (see Section 3.3.9 for a list of supplies available from the CAL) are included when indicated on the NTN FORF. In addition, the CAL supplies parts from the NADP Network Equipment Depot (NED). One of these items, the foam lid seal for the ACM collector, is replaced annually at all sites. It is also replaced if it becomes damaged. The CAL replaces other parts when they fail to operate properly. Replacement parts from the NED include the ACM motor box and sensor, the weighing mechanism and clock for the Belfort gage, and the event recorder, which records the opening and closing of the wet-side bucket of the ACM collector and is mounted in the Belfort gage.

Staff at the CAL enter data from each FORF into a database management system and check data completeness and accuracy. Field data from the FORF are combined with the chemical analytical data from the laboratory and the combined data set is reviewed. Each month Site Operators and Site Supervisors receive a preliminary data report from the CAL (see Section 4). These reports contain notes and descriptions of errors that alert Site Operators and Supervisors of potential problems or inconsistencies requiring corrections or further checks to confirm data accuracy. In addition, CAL staff screen the data to flag samples that have been grossly mishandled, are contaminated, or are not wet-deposition-only samples. Most importantly the CAL provides full-time assistance to help site personnel identify and solve equipment, operational, or procedural problems; help resolve data problems; and answer questions. Communications between site personnel and the CAL are by toll-free telephone or FAX or e-mail (see Section 7.1 for contact information). When the data verification and quality assurance checks have been completed, the data are delivered to the NADP Program Office. The CAL also conducts annual training courses for Site Operators.

2.6.2 Program Office

The NADP Program Office provides overall management of the NTN by coordinating the network activities of the Sponsoring Agencies, Operating Agencies, Site Supervisors, and Site Operators. It also manages the network quality assurance program by coordinating the quality assurance activities of the CAL, the USGS, and the USEPA. The Office receives quality-assured data from the CAL and stores and manages these data in the NADP database. Primary access to NTN data is through the NADP Web site (<http://nadp.sws.uiuc.edu>) maintained by the Program Office. The Program Office also issues data summaries, reports, and brochures, and is responsible for archiving network documents and making copies available on request. Information about locating and installing a site or site equipment and about the cost of participation in the NTN is also available from the Program Office. The Program Office manages the agreement that establishes the services provided by the CAL, and it manages the NED and provides for the repair and refurbishment of NED equipment. Other responsibilities of this Office include coordination of the activities of the NADP Technical Committee, its Subcommittees, and other Committees, and coordination with other U.S. and international networks. Finally, the Program Office is responsible for arranging the annual Site Operator training course conducted by the CAL.

2.6.3 USGS and USEPA Quality Assurance Programs

The USGS and USEPA support a number of quality assurance programs that address field site operations. Results of these programs provide the NADP Program Office, funding agencies, and site personnel with information on whether siting criteria are met, equipment meets operational specifications, standard operational procedures are followed, and measurement bias and precision meet NTN targets. Both agencies issue reports of their findings. Copies can be obtained from the NADP Program Office (see Section 7 for an address).

Current USGS and USEPA quality assurance programs are listed below and are described more completely in Section 6:

- *NTN Site Systems and Performance Surveys (ATS, Inc., under USEPA contract)*. Trained inspectors visit each site approximately every 2 years to check for siting and equipment problems, ensure that standard NTN procedures are followed, and provide Site Operators with assistance in making equipment adjustments or solving problems. At the conclusion of the visit, a brief report is delivered to the Site Operator and Supervisor, and a complete report is sent to the CAL.
- *Blind-Audit Program (USGS)*. Site Operators send the CAL a synthetic sample disguised as a wet deposition sample. The sample analysis is used to assess possible biases in NTN measurements resulting from the sample containers, handling, and analysis. A site sends one blind-audit sample to the CAL about once every other year.
- *Intersite Comparison Program (USGS)*. Site Operators report the pH and conductivity measurements of a synthetic solution of composition unknown to them. These tests are performed twice a year. Assistance is available to Operators who have problems with these measurements (see Appendix B, which deals with troubleshooting pH and conductivity measurement problems).
- *Collocated-Sampler Program (USGS)*. Site Operators run paired, collocated ACM collectors and Belfort gages, collecting two samples and changing two raingage charts each week. At the field site and at the CAL, these samples are treated independently as if from separate sites. Data from this program provide estimates of the overall precision of NTN wet deposition measurements from the point of sample collection through data verification and screening. Collocated samplers are operated at a site for 1 year; then the second set of equipment is moved to another network site.
- *Field Blank Program (USGS)*. Site Operators add a synthetic solution to the wet-side bucket at the end of a sampling period when no precipitation occurred. The Operator handles the solution as if it were a wet deposition sample, sending it to the CAL for analysis. The sample analysis is used to assess possible biases in NTN measurements from a sample container left in the ACM collector for an entire sampling period, then handled and analyzed as if it were a precipitation sample.

For a listing and contact information of the agencies and individuals involved in these programs, see Section 7.

2.7 References

Bailey, R.G. 1976. *Ecoregions of the United States*. Scale 1:7,500,000. U.S. Forest Service Intermountain Region, Ogden, UT.

Bailey, R.G. 1978. *Description of the Ecoregions of the United States*. U.S. Forest Service Intermountain Region, Ogden, UT.

NADP. 1984. *Instruction Manual: NADP/NTN Site Selection and Installation*. NADP Program Office, Champaign, IL.

NADP. 1994. *Every Tuesday Morning - 1994, NADP/NTN Deposition Monitoring Training Aid for Site Operators*. (S. Dossett and J. Frisch, eds.) NADP Program Office, Champaign, IL.

Robertson, J., and J. Wilson. 1985. *Design of the National Trends Network for Monitoring the Chemistry of Atmospheric Precipitation*. U.S. Geological Survey, Circular 964, Alexandria, VA.

3 NTN Site Operating Procedures

This section contains detailed procedures for the operation of an NTN field site. It includes information about regular equipment checks, collecting samples from the field, performing field chemistry measurements, recording data, and shipping samples to the laboratory.

Following these procedures helps to ensure the uniform, high-quality data that NTN seeks and to minimize the possibility that data will be invalidated.

3.1 General Guidelines

The success of the NTN depends upon each Site Operator's continuing commitment to follow the procedures outlined in this manual. Each Site Operator is expected to adhere to these general guidelines:

- Measure wet deposition using only an Aerochem Metrics (ACM) 301 precipitation collector and Belfort B5-780 recording raingage equipped with an event recorder.
- Maintain equipment in good working order.
- Maintain areas surrounding the collector as described in Section 5 of this manual.
- Submit prospective site or equipment moves or modifications to the Program Office for review prior to implementation.

And, most important:

- Follow the weekly Tuesday to Tuesday sample collection schedule and submit samples with a completed Field Observer Report Form (FORF) and raingage chart to the Central Analytical Laboratory (CAL) for analysis.

3.2 Field Procedures

In this section the terms *field bucket* and *sample bottle* are used. The ACM collector has side-by-side buckets, one labeled *WET* and the other *DRY* on the instrument base. The term *field bucket*, is used for the bucket installed on the *WET* side of the collector. The *sample bottle* is the 1-liter bottle used to send the sample to the CAL.

3.2.1 Preparing for Sample Collection

3.2.1.1 Check Mailer Contents upon Receipt

Each site is allocated a supply of at least six mailers. At any time two or three mailers should be available on site. **Rotate through the stock of mailers at least every 6 weeks.**

Open and inspect the black mailer from the CAL immediately upon receipt to verify that all supplies are present and in good condition. The mailer should contain:

- A 1-liter high-density polyethylene (HDPE) wide-mouth sample bottle (bagged)

- A standard NTN 3.5-gallon linear polyethylene (LPE) field bucket (bagged)
- A snap-on lid for the field bucket (bagged)
- Supplies or items you have requested via a previous FORF (see Section 3.3.9) or other items from the CAL

Remove the sample bottle from the mailer and carefully store it in its plastic zippered bag in a clean, dry place in the laboratory. **Never take the sample bottle to the field site.**

3.2.1.2 Prepare to Service Field Site

To change the bucket on the collector and service the recording raingage, take the following supplies to the field site (Figure 3-1):

- The black mailer containing the bagged field bucket and snap-on lid
- A notebook and pen to record comments about contamination in the bucket, equipment malfunctions, and activities near the site (burning, farming, etc.)
- A permanent ink marker to write comments directly onto the field bucket bag
- A few lab wipes or tissues in case something needs to be wiped clean (to remove bird droppings on the sensor, for example)
- A plastic squeeze bottle containing distilled water to activate the sensor on the ACM collector
- A raingage chart No. 5-4046-BI for the Belfort. **Note:** Use only this chart. It was especially prepared for NTN.



Figure 3-1. Pack the mailer for the field site.

3.2.2 Changing Wet-Side Field Bucket and Checking Equipment

Replace the field bucket on the collector every Tuesday morning at 0900 hours local time. Slowly and carefully change the bucket using the procedures described below. Note any contaminants present in the wet-side field bucket and precipitation in the dry-side bucket.

If precipitation occurs during the site visit, there are two collection options available, depending on time and travel schedules:

1. Collect the sample after precipitation stops. This is the easiest option if a brief shower occurs and a break in precipitation is imminent. Otherwise, the sample can be collected later on Tuesday.
2. Collect the sample during precipitation. Be careful to prevent contamination from clothing, an umbrella, the collector lid, or the bucket lid from entering the field bucket.

Time and travel schedules and steady precipitation may make option 2 necessary. If possible, wait until the precipitation slows. Whatever the situation, extra care is necessary. Unless safety is a concern, do not skip the Tuesday collection.

For inclusion in NTN summaries, samples can have sampling periods up to 194 hours in duration. If you cannot reach the site within 1 or 2 hours of 0900 hours, make sure the sampling period fits this constraint.

Never touch sampling surfaces. Precipitation samples have very low ion concentrations, and any contamination could result in unrepresentative data. For example, one drop of human perspiration invalidates a sample for sodium, chloride, ammonium, and possibly other ions. A fingerprint inside a bucket or lid may contain more sodium than the entire sample.

Check the main functions of the collector each week. These functions are the motor box *off* and *on* switching functions, the sensor heating and switching functions, and the operation of the event recorder in the raingage. Use the Precipitation Collector Maintenance Manual, Appendix C, to diagnose and resolve any problem. Contact the CAL at 1-800-952-7353 for additional help to solve the problem or determine which components require replacement and which precipitation samples may have been affected.

If the collector fails any of the function checks:

- Try to confirm that the collector is getting power.
- If the collector is cycling back and forth, unplug the sensor to see what happens.
- If the drive motor does not respond to the sensor being wet, try to push the clutch mechanism 2 or 3 inches to see what happens (see Appendix C).

3.2.2.1 Weekly Sampling Routine

1. Approach the collector and work from the downwind side to reduce windblown contaminants. Inspect the site and equipment for damage.

Initial Collector Checks

2. Check the temperature of the sensor on the collector by touching the sensor plate (Figure 3-2). Unless the collector has been open within the last few minutes, it should feel cool.

3. Inspect the dry-side bucket and note the presence of any precipitation. Large amounts of precipitation in the dry-side bucket may indicate a collector malfunction. Estimate the precipitation volume in the dry-side bucket. Later you will record this observation.



Figure 3-2. Check the sensor temperature.

4. Open the black mailer and set the lid inside up on the ground.

5. Activate the sensor grid by applying a few drops of water (Figure 3-3). **Do not use metal to short the grid as this may damage it.** The collector should open immediately, the collector lid should move to cover the dry-side bucket, and then the drive motor should turn off. Observe this movement. The collector lid should operate freely with little motor noise, and the lid seal should rest snugly on the dry-side bucket.



Figure 3-3. Activate the sensor with water.

6. After the collector has been open for at least 5 minutes, check the sensor with your finger. The sensor plate should feel warm.

7. Carefully examine the wet-side bucket for contamination. In your notebook you will make detailed notes describing any contamination (see step 10). This is very important since some contaminants, such as bird droppings or soil particles, get mixed into the sample during transport and go unnoticed. **Never remove contaminants from the bucket.**

Changing the field bucket

8. Remove the bagged snap-on lid from the black mailer. Undo the twist-tie and while grasping the lid through the outside of the bag, carefully pull the bag over your arm. Seal the lid onto the field bucket by pushing down on the center in typical “Tupperware” fashion. Be careful not to touch the inside of the lid or bucket while you snap it into place (Figure 3-4).

9. Remove the sealed field bucket from the collector. Place it into the plastic bag that previously held the clean lid and secure it with the twist tie. Set the bucket in the black mailer.

10. In the notebook and also on the outside of the plastic bag, use a permanent marker to write the site ID, date and time off, and the presence of any soil, bugs, bird droppings, etc. as described in Step 7. **Do not write on the snap-on lid or field bucket (Figure 3-5).** Note that the time of the bucket change will be used to complete two separate FORFs: (1) the previous week’s bucket *off* time and (2) new bucket *on* time.



Figure 3-4. Put the lid on the bucket.

11. Check the event recorder operation. Inspect the recording raingauge while the collector is open. Check to make sure the event recorder pen (upper pen) is in the *up* position (Figure 3-6). This position indicates that the motor box and the event recorder are both operating correctly.

12. Install the clean field bucket on the collector using the bag as a glove. **Do not touch any inside surfaces of the bucket.** Do not remove the bucket from its bag until you are ready to place it on the collector.

Final Collector Checks

13. Check to see that the sensor is hot to the touch (Figure 3-2). Blow any remaining water off the sensor. Observe the collector lid movement as it covers the wet-side bucket. It should move smoothly and complete its cycle in less than 15 seconds.

14. Check to make sure the lid seal fits snugly over the wet-side bucket (Figure 3-7). If the seal is not snug or the vinyl cover is ripped or cracked, request a new one. Call the CAL promptly and circle *lid seal pad* on the FORF (Block 9). A damaged lid seal or one that fits poorly can contaminate the sample.

If the collector fails any sensor or motor box checks, place it into bulk sampling mode (see Section 3.2.2.2) and call the CAL.

15. Prepare to transport the sample to the field laboratory. Secure the mailer lid with all four straps.

16. Transport the sample to the field laboratory carefully to prevent leakage,



Figure 3-5. Note comments on the plastic bag.

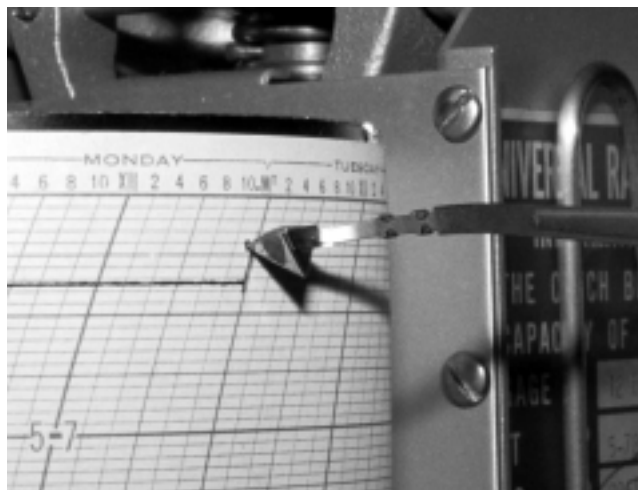

Figure 3-6. Check that event recorder pen is up.



Figure 3-7. Check the lid seal fit.

which can compromise all precipitation weight information and cause contamination. If leakage occurs, measure it as discussed in Section 3.3.6.1. The twist-tied bag will help to confine leakage. The bag also prevents packing material fibers from contaminating the sample. **Never return spilled sample to the bucket.**

If you spill the sample or drop the bucket, note this on the FORF (Block 10). Note whether the sample could have been contaminated. If the rim of the bucket or the inside of the lid contacts any foreign surfaces, the sample is potentially contaminated.

3.2.2.2 Bulk Sampling

If the ACM collector, sensor, or motor box fail to operate correctly, collect a bulk sample (see description in Section 2.3.2.2). If you collect a bulk sample, note this on the FORF (Block 10) and promptly notify the CAL. Bulk sampling requires that the wet-side bucket be uncovered for the entire sampling period.

Method A

If the collector motor box will move the collector lid, activate the sensor. When the lid is on top of the dry-side bucket and just starting to compress the lid seal, unplug the collector from all power sources.

Method B

If the collector motor box will not move the collector lid, reach under the main frame of the collector and push the clutch arm counterclockwise (see Appendix C). The clutch will disengage (a little effort may be required), and the lid mechanism will be free of the drive system. Manually position the lid over the dry-side bucket. Unplug the collector to prevent unexpected reactivation of the motor box.

3.2.3 Maintaining Dry-Side Bucket and Foam Lid Seal

On the first Tuesday of every month change the dry-side bucket when you perform the wet-side bucket change. This is necessary to help ensure a clean surface for the lid seal to rest upon during precipitation. Each site should have two 3.5-gallon LPE buckets dedicated to dry-side use: one bucket installed on the collector and the other cleaned, bagged, and ready to use as a replacement. Both buckets should be plainly marked in permanent marker: *DRY-SIDE USE ONLY*.

Caution: Using a *Dry-Side Use Only* bucket to collect a wet-side sample will invalidate the wet-side sample.

3.2.3.1 Cleaning Dry-Side Buckets at Field Laboratory

- Rinse the bucket inside and out with lots of tap water. Scrub the bucket with a sponge or paper towel to remove any debris and dirt films.

- To prevent any chemical residues from forming, do not use detergents or alcohol.
- After cleaning the bucket with tap water, rinse it with distilled water and shake off excess.
- Place the bucket in a spare CAL bag and fasten it with a twist tie.

3.2.3.2 Changing Dry-Side Buckets and Cleaning Foam Lid Seal

1. When you change the dry-side bucket, take the replacement bucket (that was cleaned as detailed in Section 3.2.3.1), a squeeze bottle with distilled water, and some lint-free tissues to the field site. If you do not have a replacement bucket, remove a clean bucket from your supply of mailers. Label it plainly with a permanent marker: *DRY-SIDE USE ONLY*, and use it as one of two dry-side buckets. Return the empty mailer to the CAL to be refilled and sent back to you.
2. Before operating the collector, remove the “old” dry-side bucket, set it aside, and note the presence of any precipitation.
3. Remove the wet-side bucket according to the instructions in Section 3.2.2.
4. While both buckets are out of the collector:
 - Assuming the sensor is wet, dry it, and if it is dry, wet it to cause the collector lid to move. When the lid is halfway between the wet-side and dry-side buckets, unplug the power to the collector.
 - Wipe the underside of the lid seal to remove any accumulated debris. Use a clean, lint-free tissue dampened with distilled water.
 - Let the foam lid seal air dry.
 - Wipe the top of the roof, the frame of the collector, and the sensor to remove bird droppings or other accumulations that could enter into the sample bucket from these surfaces.
5. Install the new *DRY-SIDE USE ONLY* bucket. Plug in the collector.
6. Install the new wet-side bucket.
7. Note which surfaces have been cleaned in Block 10 of the FORF.

If it is snowing, raining, or the site is experiencing freezing temperatures, you may not be able to use the lint-free tissue dampened with distilled water to wipe the underside of the lid seal. In these cases, dry wipe the lid seal, the top of the collector lid, the collector frame, and the sensor.

3.2.4 Nonstandard Sample Periods

Severe weather that renders the site inaccessible or unsafe may make it impossible to follow a standard sampling period. Any sampling period longer than 194 hours is invalid for NTN data summaries. However, any sample changed early, especially when heavy precipitation threatens to overflow the field bucket, is valid.

If a sample has a nonstandard period, process it, perform the field chemistry measurements, and submit it. It will be analyzed at the CAL, and the data will be made available to users on request.

Always note any variance from standard sampling in Block 10 of the FORF and adjust the Precipitation Record (Block 7) to show the precipitation amount for each day of the sampling period whether long or short. Use the following procedures to minimize the problems of nonstandard sampling periods:

- To ensure standardization among sites, samples should be from 6 to 8 days in duration. If you cannot change the bucket on Tuesday, replace it Monday (preferably late in the day) or Wednesday (preferably early in the day). This should not be a frequent practice, however.
- If heavy rain or snow threatens to fill the field bucket before the sampling period reaches 144 hours, break the sampling period into two periods. Change the bucket before it overflows (about 9 inches of rainfall), especially if more precipitation is forecast. Process each bucket independently with a separate FORF and ship it to the CAL as soon as possible. Annotate the FORF to describe incidents of snow mounding over the bucket or potential water loss due to overflow.
- When the site is inaccessible or conditions make travel unsafe, it may be necessary to collect a sample for an extended period. In this situation, change the field bucket as soon as possible. Do not skip the week and collect a 2-week sample. The raingage clock may stop and other equipment problems may result.

3.2.5 Servicing the Belfort Recording Raingage

Caution: The purple ink used in the raingage pens will stain your hands and clothes. USE CARE WHEN HANDLING IT. You may want to wear a pair of disposable gloves if extensive pen maintenance is required.

1. Open the raingage access door and move both pens up and down to mark their stop positions on the chart (Figure 3-8). The top pen is the event recorder pen, which records the openings of the collector. The bottom pen records the amount of precipitation. Note: The event recorder pen should be in the *down* position if the collector is covering the wet-side bucket and *up* if closed over the dry-side bucket. If this is not the case, call the CAL.
2. Lift the pens from the chart by pulling the pen shifter toward the access door.
3. Remove the chart drum. Record the time and date off in the appropriate place on the chart.

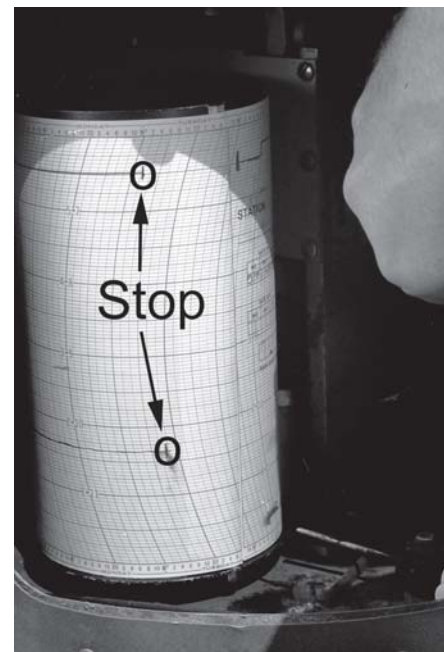

Figure 3-8. Mark the pen position.

4. Scan the event recorder trace to be sure that the collector opened and closed with each precipitation event (Figure 3-9). If the collector operated properly, the duration of the event recorder opening and the duration of precipitation will be approximately equal (see Section 3.3.7.4). **Severe collector or raingage malfunction are indicated by long *up* event recorder periods when no precipitation occurs or long *down* periods during substantial precipitation. If this is the case, call the CAL.**

5. Wind the clock. **Caution:** it is easy to overwind. Stop when you begin to feel resistance.

6. Remove and empty the catch bucket. Do not empty the bucket during winter operation because it contains antifreeze solution (see Section 5.2.2). Instead, stir the antifreeze solution to mix it well.

7. Remove the *old* chart by removing the chart clip. Store the chart in a clean, dry place where the wet ink will not be smeared.

8. Place the *new* chart on the drum:

- Fold under the right tab of the chart.
- Align the left edge of the graph section of the chart with the hole in the lower drum rim and the chart clip notch at the top of the drum.
- Wrap the chart counterclockwise around the drum.
- Insert the chart clip down through the folded (right tab) edge of the chart while keeping the clip tight against the fold.
- Lock the clip down by sliding the end through the hole in the lower drum rim and slipping the bend of the clip into the notch at the drum top.
- Using your hand, slide the chart down evenly against the drum rim.

9. Record the time and date on in the appropriate place on the chart.

10. Install the drum on the clock mechanism ensuring that the gears engage.

11. Push the pen shifter toward the chart drum. Rotate the chart drum until the precipitation pen (lower pen) reflects the local time. Mark the beginning of the precipitation and event recorder traces by moving the pens up and down.

12. Move the drum forward and back slightly to create a “+” where the chart starts.

13. Check the ink level of each pen and refill if necessary. The pen ink absorbs water from the air and can double its original volume. Be conservative when adding ink. If the lines on

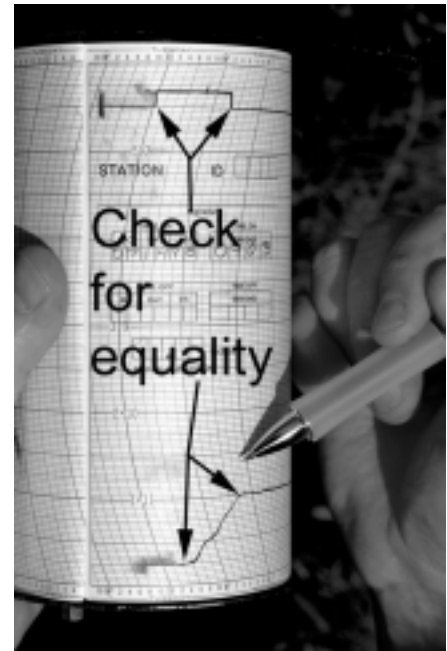

Figure 3-9. Check the operation of the event recorder.

the chart are light or smeared, the ink has possibly become diluted with water. Use tissue paper to absorb the ink from the pen nibs. Replace the diluted ink with fresh ink. **Note: Keep the ink bottle in the gage rather than carrying it back and forth each week from the laboratory.**

14. As a final check, make sure both the event recorder pen and the precipitation amount pen are recording properly.

3.2.6 Summary of Field Procedures

<i>Item</i>	<i>Procedures</i>
Wet-side bucket	<ul style="list-style-type: none"> • Inspect for contamination. • Remove from collector avoiding contact with all sampling surfaces. • Carefully install new wet-side bucket. • Pack field bucket containing sample into black mailer. • Record time, date, and contamination information on the bag containing the field bucket.
Precipitation collector	<ul style="list-style-type: none"> • Trigger sensor to uncover wet-side bucket and ensure normal operation of drive unit and sensor heater. • Inspect lid seal and dry-side bucket.
Recording raingage	<ul style="list-style-type: none"> • Remove chart and record time and date off. • Wind clock. • Compare event recorder and precipitation traces. • Install new raingage chart and note time and date on. • Start the pens inking by making a “+”.
All devices	<ul style="list-style-type: none"> • Perform any final checks and resolve any collector or raingage malfunctions. This may require help from the CAL and initiation of bulk mode sampling (see Section 3.2.2.2).

Note: If problems with equipment or procedures occur, call the CAL at 1-800-952-7353.

3.3 Completing Field Observer Report Form (FORF)

- Use the FORF (Figure 3-10) supplied by the CAL to record essential information about field and laboratory operations. This entire form (including any comments in Block 10, Remarks) is entered into the NTN database.

NEW NTN FIELD OBSERVER REPORT FORM (FORF) FOR USE STARTING JANUARY 2005

Insert this page in the NTN Site Operation Manual (July 1999 edition) in front of page 3-11.

The new FORF is shown below. Use this FORF (with a revision date of 11/04 or newer) for the first sample with a 2005 date off (01-04-2005) and dispose of any previous FORF versions.

Note the following changes:

1. The heading now includes the CAL mailing address.
2. Block 5 SAMPLE CONDITION contains a note to remind you to check the field bucket and sample bottle for contamination and to record ALL sample comments in Block 10 REMARKS.
3. Block 6 BUCKET SAMPLE WEIGHT requires that you enter the bucket weight and the lid weight separately. Always use and record the weight CAL has written on the lid and the bucket.
4. Block 8 SAMPLE CHEMISTRY is removed.
5. Block 8 is now SAMPLE BOTTLE USE.
6. Block 9 SUPPLIES has been updated to remove field chemistry supplies. Supplies have been added for the new shipping procedure in which your samples will be returned to CAL in a small cardboard box. All sites will be converted to this procedure by December 2005.



NATIONAL ATMOSPHERIC DEPOSITION PROGRAM
A Cooperative Research Support Program of the
State Agricultural Experiment Stations (NRSP-3)
Federal and State Agencies
and Private Research Organizations
<http://nadp.sws.uiuc.edu>

**NATIONAL TRENDS NETWORK
FIELD OBSERVER REPORT FORM (FORF)**

Send Completed Form with Each Sample to:
Central Analytical Laboratory, 2204 Griffith Drive, Champaign, IL 61820

Problems? Call the CAL at 1-800-952-7353
e-mail: ntn@sws.uiuc.edu or fax: 217-333-0249

FOR OFFICE USE ONLY

T							
BAG	LEAK	SP	SL	SUB			

1. SITE
Name _____ ID

2. OBSERVER
Print name _____ Initials

3. BUCKET

	Date	Time								
ON	<table border="1" style="width: 100%; border-collapse: collapse;"> <tr><td style="width: 20px;">MO</td><td style="width: 20px;">DAY</td><td style="width: 20px;">YR</td></tr> <tr><td style="height: 20px;"></td><td></td><td></td></tr> </table>	MO	DAY	YR				<table border="1" style="width: 100%; border-collapse: collapse;"> <tr><td style="width: 20px;">0001-2400</td></tr> <tr><td style="height: 20px;"></td></tr> </table>	0001-2400	
MO	DAY	YR								
0001-2400										
OFF	<table border="1" style="width: 100%; border-collapse: collapse;"> <tr><td style="width: 20px;"></td><td style="width: 20px;"></td><td style="width: 20px;"></td></tr> <tr><td style="height: 20px;"></td><td></td><td></td></tr> </table>							<table border="1" style="width: 100%; border-collapse: collapse;"> <tr><td style="width: 20px;"></td></tr> <tr><td style="height: 20px;"></td></tr> </table>		

4. SITE OPERATIONS
Check YES or NO for all samples. If NO for Item 1 or 2, describe in Block 10 and call CAL.

<table border="1" style="width: 100%; border-collapse: collapse;"> <tr><td style="width: 20px;">YES</td><td style="width: 20px;">NO</td></tr> <tr><td style="width: 20px;">2</td><td style="width: 20px;">1</td></tr> <tr><td style="width: 20px;">2</td><td style="width: 20px;">1</td></tr> </table>	YES	NO	2	1	2	1	<table border="1" style="width: 100%; border-collapse: collapse;"> <tr><td style="width: 20px;">YES</td><td style="width: 20px;">NO</td></tr> <tr><td style="width: 20px;">2</td><td style="width: 20px;">1</td></tr> <tr><td style="width: 20px;">2</td><td style="width: 20px;">1</td></tr> </table>	YES	NO	2	1	2	1	<table border="1" style="width: 100%; border-collapse: collapse;"> <tr><td style="width: 20px;">YES</td><td style="width: 20px;">NO</td></tr> <tr><td style="width: 20px;">2</td><td style="width: 20px;">1</td></tr> <tr><td style="width: 20px;">2</td><td style="width: 20px;">1</td></tr> </table>	YES	NO	2	1	2	1	
YES	NO																				
2	1																				
2	1																				
YES	NO																				
2	1																				
2	1																				
YES	NO																				
2	1																				
2	1																				
1. Bird droppings	2. Cloudy or discolored	3. Soot/ash/dirt particles	4. Insects/animal matter																		
5. Leaves/twigs/pollen/plant matter																					
6. Handling contamination																					

After decanting into sample bottle, look closely at sample and field bucket and double-check your entry.

6. BUCKET SAMPLE WEIGHT
Weigh ALL sample buckets.

Bucket + Lid + Sample	•	<input style="width: 20px;" type="text"/>	<input style="width: 20px;" type="text"/>	<input style="width: 20px;" type="text"/>	<input style="width: 20px;" type="text"/>	<input style="width: 20px;" type="text"/>	<input style="width: 20px;" type="text"/>
-	•	CAL Bucket	<input style="width: 20px;" type="text"/>	<input style="width: 20px;" type="text"/>	<input style="width: 20px;" type="text"/>	<input style="width: 20px;" type="text"/>	<input style="width: 20px;" type="text"/>
-	•	CAL Lid	<input style="width: 20px;" type="text"/>	<input style="width: 20px;" type="text"/>	<input style="width: 20px;" type="text"/>	<input style="width: 20px;" type="text"/>	<input style="width: 20px;" type="text"/>
=	•	Sample Weight (grams)	<input style="width: 20px;" type="text"/>	<input style="width: 20px;" type="text"/>	<input style="width: 20px;" type="text"/>	<input style="width: 20px;" type="text"/>	<input style="width: 20px;" type="text"/>

7. PRECIPITATION RECORD

← Bucket On R – Rain Only (Includes Hail) S – Snow Only M – Mixture U – Unknown Bucket Off →

	TUES	WED	THURS	FRI	SAT	SUN	MON	TUES
Type circle one →	R S M U	R S M U	R S M U	R S M U	R S M U	R S M U	R S M U	R S M U
Amount inches OF circle one →	●	●	●	●	●	●	●	●
	Z T MM	Z T MM	Z T MM	Z T MM	Z T MM	Z T MM	Z T MM	Z T MM
	Z – Zero T – Trace (Circle Type) MM – Missing							

Sample Weight (grams) X 0.00058 inches/gram = ← Do these values agree within ±5%? →

Sample Depth (inches) YES NO (If no, reweigh) Total Raingage Depth (inches)

8. SAMPLE BOTTLE USE

Pour ANY and ALL liquid up to 1-liter into the sample bottle.

Did you pour anything into the bottle?
YES NO

9. SUPPLIES Request early. Circle if needed, until received.

- CAL Address Labels
- Used Material Labels
- Packing Tape
- Field Forms
- Raingage Charts
- Raingage Ink
- Gloves (S, M, L)
- Dashpot Fluid
- Lid Seal Pad

10. REMARKS For example: equipment malfunction, contamination, farming, burning, logging, leakage before weighing, etc.



Rev. 11/04

**NATIONAL TRENDS NETWORK
 FIELD OBSERVER REPORT FORM (FORF)**

Send Completed Form with Each Mailer
 Problems? Call the CAL at 1-800-952-7353, or
 e-mail: sdossett@uiuc.edu, or fax: 217-333-0249

FOR OFFICE USE ONLY

N						
BAG	LEAK	SP	SL			

1. SITE Name _____ ID

--	--	--	--

2. OBSERVER Print name _____ Initials

--	--	--

3. BUCKET

ON	Date			Time		
	MO	DAY	YR	0001-2400		
OFF						

4. SITE OPERATIONS

YES	NO
2	1
2	1
2	1

Check yes or no for all samples. If no for Item 1 or 2, describe in Block 10 and call CAL.

- The **sensor heater** and **motor box** operated properly and the **event recorder** indicates the collector lid opened and closed promptly for each precipitation event.
- Raingage operated properly during the week.
- Collector opened and closed at least once during the week, **other than for testing**.

5. SAMPLE CONDITION

Check yes or no for all samples. Describe all contamination in Block 10, including any not listed here.

YES	NO
2	1
2	1

- Bird droppings
- Cloudy or discolored
- Soot/ash/dirt particles
- Insects/animal matter
- Leaves/twigs/pollen/plant matter
- Handling contamination

6. BUCKET SAMPLE WEIGHT

Weigh all sample buckets.

--	--	--	--	--	--	--	--	--	--

Bucket + Lid + Sample

--	--	--	--	--	--	--	--	--	--

Bucket + Lid

=

--	--	--	--	--	--

 X 0.00058 inches/gram =

--	--	--	--	--	--

 Sample Depth (inches)

7. PRECIPITATION RECORD

← Bucket On R - Rain Only (Includes Hail) S - Snow Only M - Mixture U - Unknown Bucket Off →

Type	TUES		WED		THURS		FRI		SAT		SUN		MON		TUES						
circle one →	R	S	M	U	R	S	M	U	R	S	M	U	R	S	M	U	R	S	M	U	
Amount																					
Inches or circle one →																					
	Z	T	MM	Z	T	MM	Z	T	MM	Z	T	MM	Z	T	MM	Z	T	MM	Z	T	MM

Z - Zero T - Trace MM - Missing

Do these values agree within ± 5% ? YES NO (If no, reweigh)

Total Raingage Depth (inches)

--	--	--	--	--	--

BOTTLE USE

Did you pour sample into the bottle? YES NO

8. SAMPLE CHEMISTRY

Only for buckets with a sample weight of 70 grams or more.

7	5	0
---	---	---

Standard Certified

--	--	--	--

Standard Measured

--	--	--	--

Correction Factor

--	--	--	--

Check Sample Measured

--	--	--	--

Check Sample Corrected

--	--	--	--

Precipitation Sample Measured

--	--	--	--

Precipitation Sample Corrected

pH

--	--	--	--

Check Sample pH

--	--	--	--

Precipitation Sample pH

9. SUPPLIES

Circle if needed, until received.

Vials	Field Forms
pH Electrode	Sample Bottles
pH 4 Buffer	Gloves (S, M, L)
pH 7 Buffer	Raingage Charts
Check Sample	Raingage Ink
75 μS/cm Std	Dashpot Fluid
Electrode Filling Solution	Lid Seal Pad

10. REMARKS For example: equipment malfunction, contamination, farming, burning, logging, leakage before weighing, etc.

Figure 3-10. Field Observer Report Form.

- Complete the FORF using either a ballpoint pen or a sharp No. 2 pencil. Be certain that notations are legible on **all** copies and that the form is **completely** filled out.
- Do not fill out the FORF on top of other blank FORFs.
- Incomplete or illegible FORFs require additional time to process and usually require phone inquiries to the Site Operator or Site Supervisor from the CAL.
- Site Operators should use **two FORFs** each week. One contains the information gathered at the field site for the week just ending. The other is for the week just beginning. This will reduce date and time errors and help substitute Observers complete the forms without errors.

3.3.1 SITE, Block 1

1. SITE Name _____	<table border="1" style="margin: auto;"> <tr> <td style="width: 20px; height: 20px;"></td> <td style="width: 20px; height: 20px;"></td> <td style="width: 20px; height: 20px;"></td> <td style="width: 20px; height: 20px;"></td> </tr> </table> ID				

Figure 3-11. Block 1.

Fill in the Site Name and ID as assigned (Figure 3-11). Site Names are chosen during the site selection and installation process. The Site ID is a four-character code.

3.3.2 OBSERVER, Block 2

2. OBSERVER Print name _____	<table border="1" style="margin: auto;"> <tr> <td style="width: 20px; height: 20px;"></td> <td style="width: 20px; height: 20px;"></td> <td style="width: 20px; height: 20px;"></td> </tr> </table> Initials			

Figure 3-12. Block 2.

Print the name and initials of the person to whom the CAL should direct questions concerning the week’s sample and site operations. Use three initials whenever possible (Figure 3-12).

3.3.3 BUCKET ON/OFF, Block 3

3. BUCKET	<table border="1" style="margin: auto; text-align: center;"> <tr> <th colspan="6">Date</th> </tr> <tr> <th style="width: 15%;">MO</th> <th style="width: 15%;">DAY</th> <th style="width: 15%;">YR</th> <th style="width: 15%;"> </th> <th style="width: 15%;"> </th> <th style="width: 15%;"> </th> </tr> <tr> <td style="height: 20px;"></td> <td style="height: 20px;"></td> <td style="height: 20px;"></td> <td style="height: 20px;"></td> <td style="height: 20px;"></td> <td style="height: 20px;"></td> </tr> <tr> <td style="height: 20px;"></td> <td style="height: 20px;"></td> <td style="height: 20px;"></td> <td style="height: 20px;"></td> <td style="height: 20px;"></td> <td style="height: 20px;"></td> </tr> </table>	Date						MO	DAY	YR																<table border="1" style="margin: auto; text-align: center;"> <tr> <th colspan="4">Time</th> </tr> <tr> <th colspan="4">0001-2400</th> </tr> <tr> <td style="width: 20px; height: 20px;"></td> <td style="width: 20px; height: 20px;"></td> <td style="width: 20px; height: 20px;"></td> <td style="width: 20px; height: 20px;"></td> </tr> <tr> <td style="height: 20px;"></td> <td style="height: 20px;"></td> <td style="height: 20px;"></td> <td style="height: 20px;"></td> </tr> </table>	Time				0001-2400											
Date																																										
MO	DAY	YR																																								
Time																																										
0001-2400																																										
ON																																										
OFF																																										

Figure 3-13. Block 3.

Record the date (month/day/year) and local time when the field bucket was installed (ON) and removed (OFF). Figure 3-13 defines the sampling period. Use 24-hour time, which runs from 0001 to 2400 hours. Therefore 9:00 a.m. is 0900 hours and 5:00 p.m. is 1700 hours. Declarations of standard or daylight-savings time are not necessary.

3.3.4 SITE OPERATIONS, Block 4

Because the Site Operator is the only one who observes the condition of the equipment in the field, it is crucial to obtain the Operator's assessment of field equipment performance.

4. SITE OPERATIONS									
<i>Check yes or no for all samples. If no for Item 1 or 2, describe in Block 10 and call CAL.</i>									
<table border="1"> <thead> <tr> <th>YES</th> <th>NO</th> </tr> </thead> <tbody> <tr> <td>2</td> <td>1</td> </tr> <tr> <td>2</td> <td>1</td> </tr> <tr> <td>2</td> <td>1</td> </tr> </tbody> </table>	YES	NO	2	1	2	1	2	1	<ol style="list-style-type: none"> The sensor heater and motor box operated properly and the event recorder indicates the collector lid opened and closed promptly for each precipitation event. Raingage operated properly during the week. Collector opened and closed at least once during the week, other than for testing.
YES	NO								
2	1								
2	1								
2	1								

Figure 3-14. Block 4.

Check *Yes* or *No* for each question in Block 4 (Figure 3-14). Answers to these questions and the comments provided in Block 10 are used to decide whether the sample is valid. For questions 1 and 2, a *Yes* indicates correct site operations, while a *No* indicates problems that must be documented in Block 10. **Notify the CAL by telephone (1-800-952-7353) when responses to questions 1 or 2 are *No*.**

Question 1 addresses the collector. Answer *No* if the checks performed during the bucket change uncovered any malfunctions in the sensor heater, motor box switching, or event recorder mechanisms.

Question 2 addresses the raingage. Answer *No* if the clock did not perform accurately during the sampling period or the pens did not trace correctly on the chart.

Question 3 requires a response **only if the site is equipped with a properly working event recorder**. Check *Yes* if something other than a test triggered the sensor and caused the roof mechanism to uncover the wet-side bucket. If the event recorder is inoperative, leave this response box blank.

3.3.5 SAMPLE CONDITION, Block 5

- Complete Block 5 (Figure 3-15) for **all samples** even if the bucket is dry.
- **Never attempt to remove any contaminant, no matter how large, from a bucket.**
- In Block 10, describe all contaminants observed in the field bucket.

5. SAMPLE CONDITION							
<i>Check yes or no for all samples. Describe all contamination in Block 10, including any not listed here.</i>							
<table border="1"> <thead> <tr> <th>YES</th> <th>NO</th> </tr> </thead> <tbody> <tr> <td>2</td> <td>1</td> </tr> <tr> <td>2</td> <td>1</td> </tr> </tbody> </table>	YES	NO	2	1	2	1	<ol style="list-style-type: none"> Bird droppings Cloudy or discolored
YES	NO						
2	1						
2	1						
	<table border="1"> <thead> <tr> <th>YES</th> <th>NO</th> </tr> </thead> <tbody> <tr> <td>2</td> <td>1</td> </tr> <tr> <td>2</td> <td>1</td> </tr> </tbody> </table> <ol style="list-style-type: none"> In In 	YES	NO	2	1	2	1
YES	NO						
2	1						
2	1						

Figure 3-15. Block 5.

Block 5 provides important information about contaminants in the field bucket before the precipitation is transferred to the sample bottle. These become mixed during transit and may not be

visible when the sample bottle arrives at the CAL. This information cannot be obtained unless you record it.

Use information recorded in field notebooks and on the bag protecting the field bucket to fill out this block. Observations should have been made at the site before placing the lid on the field bucket, while it was still in the collector.

Check each box *Yes* or *No* and enter comments regarding the type, size, and amount of contaminants in Block 10. Some may not be identifiable as either animal or plant in origin. It is not necessary to know the exact source of a contaminant.

Note: The CAL does not automatically invalidate the sample because of the presence of contaminants.

3.3.6 BUCKET SAMPLE WEIGHT, Block 6

- In the laboratory remove the field bucket from the black mailer and plastic bag. Leave the bucket lid on during this step. Save the bag for use later.
- Do not spill or discard any water or snow that may be in the bag. Any sample that has leaked from the field bucket must be measured.

Weigh all buckets whether or not they contain precipitation and record information in Block 6 (Figure 3-16).

6. BUCKET SAMPLE WEIGHT
Weigh all sample buckets.

<input type="text"/>	<input type="text"/>	<input type="text"/>	<input type="text"/>	<input type="text"/>	<input type="text"/>	•	<input type="text"/>	Bucket + Lid + Sample
-	<input type="text"/>	<input type="text"/>	<input type="text"/>	<input type="text"/>	<input type="text"/>	•	<input type="text"/>	Bucket + Lid
<hr/>								
<input type="text"/>	<input type="text"/>	<input type="text"/>	<input type="text"/>	<input type="text"/>	<input type="text"/>	•	<input type="text"/>	Sample Weight (grams)

Figure 3-16. Block 6.

3.3.6.1 Measure Any Leakage

- If any sample leaked into the bag during transport, you must measure the leakage. First, weigh the bag containing the leakage, and then the bag alone. Obtain the weight of the leakage by subtracting the bag weight from the bag weight plus leakage. An alternative method is to pour the lost liquid into a graduated cylinder and measure its volume. Recall that 1 milliliter (mL) of water is equal to 1 gram (Figure 3-17).
- Note the occurrence of any leakage and its exact amount in Block 10 of the FORF. This amount will be added to the *Bucket + Lid + Sample* weight in the next step. Be as specific about the circumstances of the leakage as possible. For example, when and how did the field bucket leak, and could the sample have been contaminated?
- After weighing and recording any leakage, discard the lost water. **Do not return it to the sample bucket.**

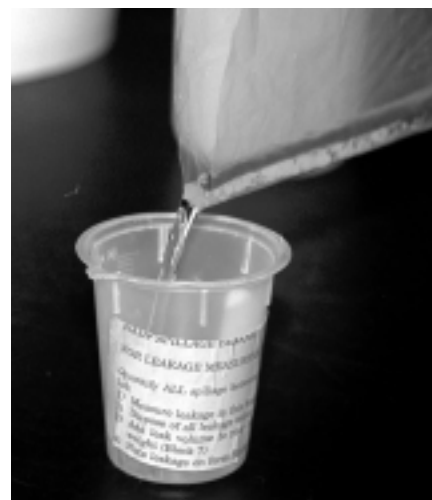

Figure 3-17. Measure sample leakage.

signed to accommodate a standard Tuesday to Tuesday sampling period. If a nonstandard period needs to be reported, follow these general rules:

- If the sampling period exceeds 1 week, attach an additional FORF and carefully note the extra days. For example, with a Tuesday to Wednesday sample, fill out the first form for all 8 days (Tuesday to Tuesday) and add a form to report the second Wednesday. On this second form cross out all nonapplicable days (i.e., the first Tuesday and then Thursday through the second Tuesday).
- If the sampling period is less than 1 week, carefully note the correct starting day and cross out nonapplicable days. For example, for a Wednesday to Tuesday sample, cross out the first Tuesday in Block 7, and then fill out the rest of the week.

3.3.7.1 Precipitation Type

- Circle one *Type* of precipitation for each day with precipitation, even a trace.
- Circle *R* if only rain occurred, *S* if only snow occurred, and *M* for any combinations, including sleet and freezing rain. Record hail as *R* and document its occurrence in Block 10.
- Circle *U* (unknown) for those instances when you do not know the precipitation type.
- Fog, dew, and frost are not considered precipitation. Do not report them as trace amounts. Instead, note them in Block 10.

3.3.7.2 Precipitation Amounts

- Record the *Amount* of precipitation each day to the nearest 0.01 inch.
- On the first day of the sampling period (Tuesday), report only the precipitation that occurred after the bucket was installed (e.g., from 0900 to 2400 hours).
- On the last day of the sampling period, report only the precipitation that occurred before the bucket was taken off (e.g., from 0001 to 0900 hours).
- If no precipitation occurred, circle *Z* and do not record zeroes for the amount.
- Circle *T* in those instances where a trace amount of precipitation occurred (less than 0.01 inches).
- Circle *MM* to indicate that the information is missing. Describe the reason for the missing amounts in Block 10. Further, if the amount is missing because the raingage wasn't operating properly, you should have checked *No* for question 2 in Block 4.

In the lower right corner of Block 7 (Figure 3-18), record the *Total Raingage Depth (inches)*. This value should be the sum of all of the daily precipitation amounts from *Bucket On* to *Bucket Off*. Count trace amounts as zero in the addition unless the *Total Raingage Depth* is a trace, then write trace in this space. **If any daily values are missing, leave the *Total Raingage Depth* blank.**

3.3.7.3 Weight Recheck and Collection Efficiency

Compare the *Total Raingage Depth (inches)* to the *Sample Depth (inches)* in the lower portion of Block 7 (Figure 3-19). Obtain *Sample Depth (inches)* by multiplying the *Sample Weight (grams)* x 0.00058 inches/gram. Calculate the percent difference between the two numbers and answer the question, *Do these values agree within ± 5 percent?* Use the following equation.

$$\frac{\text{total raingage depth (inches) minus sample depth (inches)}}{\text{total raingage depth (inches)}} \times 100\% = \text{percent difference}$$

$=$ <table style="display: inline-table; border: none;"> <tr> <td style="border: 1px solid black; width: 20px; height: 20px;"></td> <td style="border: 1px solid black; width: 20px; height: 20px;"></td> <td style="border: 1px solid black; width: 20px; height: 20px;"></td> <td style="border: 1px solid black; width: 20px; height: 20px;"></td> <td style="border: 1px solid black; width: 20px; height: 20px;"></td> <td style="border: 1px solid black; width: 20px; height: 20px;"></td> <td style="border: 1px solid black; width: 20px; height: 20px;"></td> <td style="border: 1px solid black; width: 20px; height: 20px;"></td> <td style="border: 1px solid black; width: 20px; height: 20px;"></td> <td style="border: 1px solid black; width: 20px; height: 20px;"></td> <td style="border: 1px solid black; width: 20px; height: 20px;"></td> <td style="border: 1px solid black; width: 20px; height: 20px;"></td> </tr> <tr> <td colspan="11" style="text-align: center; font-size: 8px;">Sample Weight (grams)</td> </tr> </table> $\times 0.00058 \text{ inches/gram} =$ <table style="display: inline-table; border: none;"> <tr> <td style="border: 1px solid black; width: 20px; height: 20px;"></td> <td style="border: 1px solid black; width: 20px; height: 20px;"></td> <td style="border: 1px solid black; width: 20px; height: 20px;"></td> <td style="border: 1px solid black; width: 20px; height: 20px;"></td> <td style="border: 1px solid black; width: 20px; height: 20px;"></td> <td style="border: 1px solid black; width: 20px; height: 20px;"></td> <td style="border: 1px solid black; width: 20px; height: 20px;"></td> <td style="border: 1px solid black; width: 20px; height: 20px;"></td> <td style="border: 1px solid black; width: 20px; height: 20px;"></td> <td style="border: 1px solid black; width: 20px; height: 20px;"></td> <td style="border: 1px solid black; width: 20px; height: 20px;"></td> <td style="border: 1px solid black; width: 20px; height: 20px;"></td> </tr> <tr> <td colspan="11" style="text-align: center; font-size: 8px;">Sample Depth (inches)</td> </tr> </table> \leftarrow													Sample Weight (grams)																							Sample Depth (inches)											Do these values agree within $\pm 5\%$? YES <input type="checkbox"/> NO <input type="checkbox"/> (if no, reweigh)	\rightarrow <table style="display: inline-table; border: none;"> <tr> <td style="border: 1px solid black; width: 20px; height: 20px;"></td> <td style="border: 1px solid black; width: 20px; height: 20px;"></td> <td style="border: 1px solid black; width: 20px; height: 20px;"></td> <td style="border: 1px solid black; width: 20px; height: 20px;"></td> <td style="border: 1px solid black; width: 20px; height: 20px;"></td> <td style="border: 1px solid black; width: 20px; height: 20px;"></td> <td style="border: 1px solid black; width: 20px; height: 20px;"></td> <td style="border: 1px solid black; width: 20px; height: 20px;"></td> <td style="border: 1px solid black; width: 20px; height: 20px;"></td> <td style="border: 1px solid black; width: 20px; height: 20px;"></td> <td style="border: 1px solid black; width: 20px; height: 20px;"></td> <td style="border: 1px solid black; width: 20px; height: 20px;"></td> </tr> <tr> <td colspan="11" style="text-align: center; font-size: 8px;">Total Raingage Depth (inches)</td> </tr> </table>													Total Raingage Depth (inches)										
Sample Weight (grams)																																																																							
Sample Depth (inches)																																																																							
Total Raingage Depth (inches)																																																																							

Figure 3-19. Lower portion of Block 7, weight recheck.

If the values do not agree within ± 5 percent, recheck all sample weights and calculations in Block 6. Record this recheck procedure in Block 10 and revise the weights as necessary.

If the precipitation was in the form of rainfall, the balance is accurate, and more than 0.5 inches of precipitation occurred during the sampling period, the two values should agree within ± 5 percent. In the event of snow or mixed precipitation, it is quite common for the collector to miss more than 5 percent of the precipitation.

The CAL has no way of correcting the error if the *Bucket + Lid + Sample* weight is wrong. It is up to you to double-check the weights. Notify the CAL immediately if you suspect equipment problems may account for the differences.

3.3.7.4 Detailed Interpretation of Precipitation and Event Recorder Traces

See Figure 3-20 for a sample raingage chart. Interpretation of the chart by the Site Operator provides the network with two important pieces of information: precipitation quantity and field bucket exposure.

- The lower line on the chart records the irregular pattern of weight addition to the gage corresponding to the accumulation of precipitation in the catch bucket. This record will be divided into daily precipitation amounts and then summed. As discussed in Section 3.3.7.3, this sum is recorded on the FORF as *Total Raingage Depth (inches)* and should agree within ± 5 percent of the *Sample Depth (inches)*.
- The upper line on the chart reveals whether the collector lid opening and closing coincides with precipitation events through the tracings of the event recorder. This coincidence defines collection of a *wet-deposition only sample* as described in Section 2.3.2.1. Report large or persistent discrepancies between the opening and closing of the wet-side bucket and the occurrence of precipitation to the CAL as soon as possible and record them in Block 10.

3.3.7.4.1 Chart Features

Figure 3-21 is a raingage chart section. The chart covers daily periods along its horizontal axis. Vertical scaling of the chart is in inches printed along the major divisions of the chart: e.g., 1-11 and

CHART NO. 5-4046-BI
 12 INCH DUAL TRAVERSE 192 HOURS
 UNIVERSAL RAIN GAGE
 BELFORT INSTRUMENT COMPANY
 BALTIMORE, MARYLAND, U.S.A.

PRINTED IN U.S.A.



PRECIPITATION RECORD

REMARKS

Figure 3-20. Sample raingage chart.

2-10. The chart is designed for a dual traverse raingage, and the number before the hyphen indicates the amount as the pen swings upward recording 0 to 6 inches of precipitation. The number after the hyphen indicates additional precipitation as the pen swings downward, recording 6 to 12 inches of precipitation. Record the Site ID and the chart's period of record in the spaces indicated at the top of the chart.

- Each vertical chart division represents 0.05 inches of precipitation. The maximum resolution of the chart is 0.01 inches and depends upon the Site Operator's ability to evaluate the traces. Ideally, a Site Operator can resolve each rainfall event to within approximately 0.02 inches.
- Each horizontal chart division represents 2 hours. The maximum resolution is about 15 minutes.

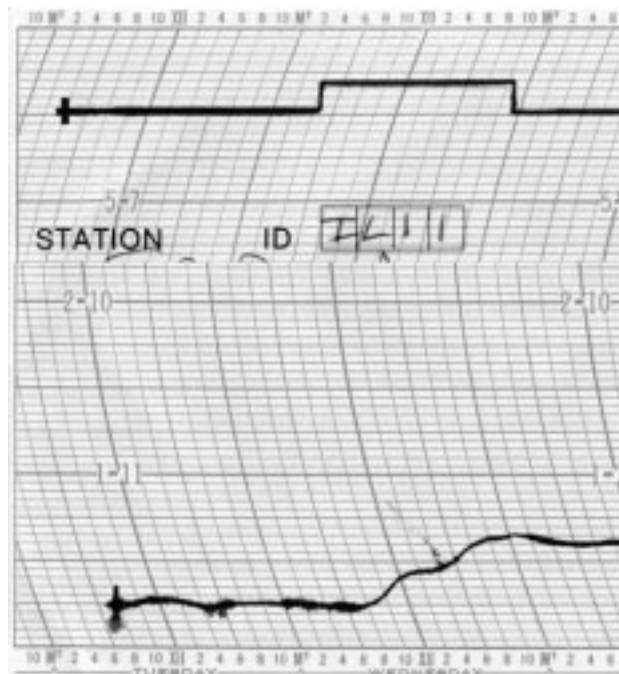

Figure 3-21. Raingage chart section.

3.3.7.4.2 Event Recorder Transcription

By design, the event recorder trace lags behind the precipitation record by 4 to 6 hours so that the two pens do not interfere with each other as the precipitation pen nears its upper limit. Because of this lag it is best to transcribe the event recorder trace onto the precipitation trace to check their agreement (Figure 3-22).

1. Lay the top left corner of the FORF against the left side of the event recorder trace, and use a pen or pencil to mark on the top edge of the FORF periods when the field bucket was open.
2. Slide the FORF down to the precipitation trace. Align the top left corner of the FORF with the beginning of the precipitation record. Now the two traces coincide in time.
3. Mark the precipitation record to show the open and closed periods of the collector. When transferring the event recorder trace, be certain to follow the curve of the time line; the FORF cannot simply be moved straight up. To do this, mark a time reference at Friday noon on the FORF, and when sliding the FORF up (to follow precipitation events as the trace climbs through the week), be certain to keep the time reference on Friday noon.

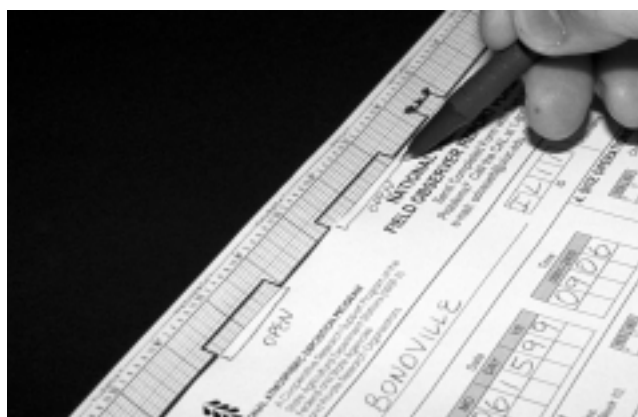

Figure 3-22. Transcribe event recorder trace.

Now that the event recorder trace is superimposed upon the precipitation line, you should be able to confirm that the opening period of the field bucket matches the incidence of precipitation. If this is not the case, check *No* for Block 4, Question 1 (see Section 3.3.4) and call the CAL.

3.3.7.4.3 Reading the Raingage Chart

Starting at Tuesday's 0 numbered event (Figure 3-23), note that the position of the lower trace moves up and down during the day. Up to 0.05 inches of drift on the chart is normal, a result of the heating and cooling of the metal components of the raingage. Chart paper may also expand and contract due to changes in humidity. If precipitation had occurred, the event recorder would have risen. Judgment must be exercised in these cases to know that the collector did not simply fail to open for precipitation. It is useful to note that this drift occurs most often with hot days and cool nights.

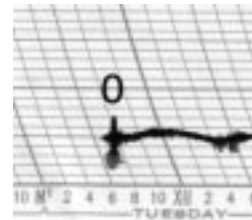

Figure 3-23. Chart point 0.

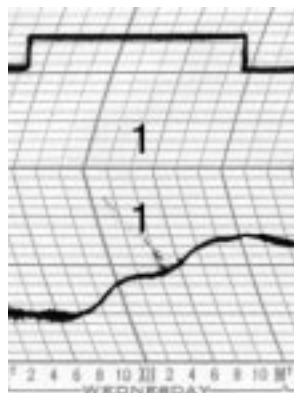

Figure 3-24. Chart point 1.

Event 1 (Figure 3-24) shows how the event recorder works when the field bucket is exposed. The event pen (top line) steps up as the collector opens at the start of a precipitation event and drops when the event is over. The precipitation amount is measured from the start of the rise in the raingage trace (bottom line) to the end of the rise. Event 1 started about 0800 hours Wednesday and lasted until midnight (2400 hours), leaving 0.42 inches of precipitation.

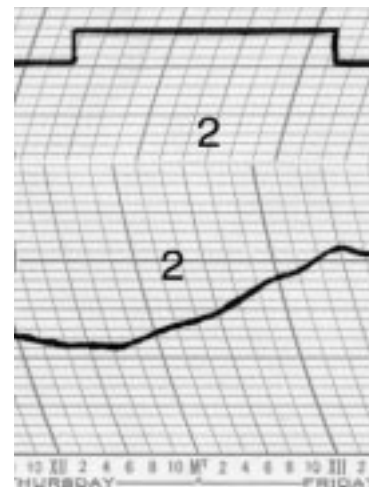

Figure 3-25. Chart point 2.

Precipitation during Event 2 (Figure 3-25) is also measured from the start to the end of the rising trace. It does not include the rise of Event 1 or the 0.08 inch drop between the end of Event 1 and the beginning of Event 2. This drop may be due to temperature drift or evaporation, but the cause is not important to the evaluation of the precipitation received. **What is important is to determine the magnitude of each precipitation event. Note that this “event” will be split between Thursday and Friday.**

Event 3 is similar to Event 2. The event recorder confirms the operation of the collector on the top line.

Event 4 (Figure 3-26), you must understand exactly what the event recorder does. Its function is to record the time when the field bucket is uncovered and exposed to the atmosphere (the collector is open). It does not record the start and stop or duration of precipitation events. In this case, the event recorder indicates that the collector did open, but it is not clear that a measurable amount (0.01 inches or more) of precipitation occurred. It is possible that the collector sensor detected a small event that the raingage did not record. Unless you think otherwise, record precipitation during Event 4 as a trace amount.

To interpret Event 4 (Figure 3-26), you must understand exactly what the event recorder does. Its function is to record the time when the field bucket is uncovered and exposed to the atmosphere (the collector is open). It does not record the start and stop or duration of precipitation events. In this case, the event recorder indicates that the collector did open, but it is not clear that a measurable amount (0.01 inches or more) of precipitation occurred. It is possible that the collector sensor detected a small event that the raingage did not record. Unless you think otherwise, record precipitation during Event 4 as a trace amount.

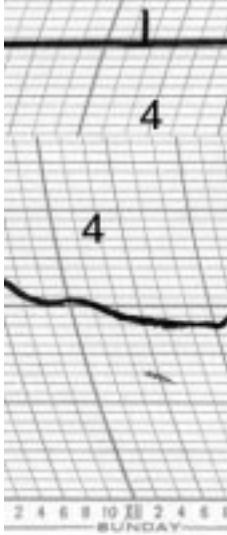

Figure 3-26.
Chart point 4.

Event 5 is similar to Events 2 and 3. This sequence illustrates the fall of the raingage trace due to evaporation. Remember that this drop must not be counted when determining the daily precipitation amount. During Event 5, 0.21 inches of precipitation occurred.

Events 6 and 7 are similar to Event 4 and reflect the type of trace expected during periods of intermittent drizzle or heavy fog. The collector opens frequently or stays open for a short time while no appreciable precipitation occurs.

Event 8 (Figure 3-27) is not a precipitation event, but a *test* event: the Site Operator activates the sensor, causing the collector to open in order to change field buckets. A *test* event should appear at both ends of the sampling period.

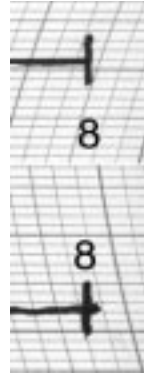

Figure 3-27.
Chart point 8.

3.3.7.4.4 Reporting Daily Precipitation Amounts: Arranging Events to Fit Field Form

Tables 3-1 and 3-2 list the amount of precipitation for each event and the total for the week. To complete Block 7, the precipitation event record must be arranged into daily precipitation amounts and summed.

To arrange daily values:

- Add events: Events 5 and 6 occurred on the same day.
- Split an event: Event 2 spanned 2 days.

To sum the total for the week:

- Simply add each daily value.
- Ignore traces.

Table 3-1. Chart Precipitation Record

<i>Event No.</i>	<i>Precipitation amount (inches)</i>
1	0.42 (all Wednesday)
2	0.07 (to Thursday) 0.42 (to Friday)
3	0.23 (all Saturday)
4	Trace
5	0.26 (to Monday)
6	0.02 (to Monday)
7	Trace
8	Test
Total	1.42

Table 3-2. Daily Precipitation Record

<i>Day</i>	<i>Precipitation amount (inches)</i>
Tuesday	0 (circle Z)
Wednesday	0.42
Thursday	0.07
Friday	0.42
Saturday	0.23
Sunday	Trace (circle T)
Monday	0.28
Tuesday	0 (circle Z)
Total	1.42

3.3.8 SAMPLE CHEMISTRY, Block 8

3.3.8.1 Transferring Liquid from Field Bucket

Transfer all samples of any volume, even a few drops, to the 1-liter sample bottle. There is no minimum amount for transfers. **The CAL does not analyze samples that are not poured into a sample bottle.**

Transferring the sample from the field bucket to the sample bottle requires that the sample be decanted. To decant a solution is to allow it to stand undisturbed so that debris settles out. The clean liquid is then poured from one container to another, allowing the debris to remain behind.

As with the field buckets and lids, use only CAL-cleaned sample bottles. If a bottle or cap becomes contaminated during sample transfer, replace it with a clean one. **Never attempt to rinse or otherwise reuse a bottle suspected of contamination.** Simply return the bottle to the CAL in a bag clearly marked “to be cleaned.”

- **Do not decant until the bucket contents are completely thawed.**
- **Do not agitate the field bucket.** Leave any settled debris behind and describe these in Blocks 5 and 10 of the FORF.

3.3.8.1.1 Decanting into Sample Bottle

1. Place a clean tray or other flat-bottomed pan on the laboratory bench or counter. Be sure the tray or pan is large enough to hold any spilled water.
2. Remove the 1-liter sample bottle from its bag and place it in the center of the tray or pan. Save the bag for use in shipping.
3. Put on a pair of the disposable gloves provided by the CAL. Keep the glove fingertips and palms clean.
4. Remove the bottle cap and set it aside **inside up** (top of the cap down) on a clean disposable lab wipe or tissue. Do not touch the inside surfaces of the bottle or cap or the rim of the bottle.
5. Remove the snap-on lid from the field bucket. Avoid contact with the bucket and lid rim.
6. Remove and discard your gloves.
7. Visually inspect the contents of the bucket for debris. This will be the last opportunity to identify contamination in the bucket. Note any contaminants in Blocks 5 and 10 of the FORF.

8. Grasp the bucket by the sides (not the handle or rim) and carefully decant the sample into the 1-liter bottle (Figure 3-28). Pour from the side opposite from which the lid was pried off the bucket. Keep the lip of the bucket above the sample bottle rim so that the bucket and bottle do not make contact. Be sure to hold the bucket handle against the bucket so that it does not swing down and overturn the sample bottle. Avoid leaning over the field bucket or sample bottle while decanting.



Figure 3-28. Decant the liquid.

9. Fill the sample bottle only up to the shoulder (about 1 inch below the top). If the bottle is filled further, the sample may freeze and break it during cold season shipment. Carefully screw the cap onto the bottle until it is snug.
10. Secure the snap-on lid to the field bucket and set it carefully aside. In the event of a spill from the sample bottle, any leftover sample in the field bucket may be used to fill another *new* sample bottle. Therefore, save the liquid in the bucket until you have completed the measurements and are preparing to ship the sample.

11. Discard any spilled sample. Do not pour it back into the sample bottle or field bucket. Note spillage on Block 10 of the FORF.

3.3.8.1.2 Sample Bottle Usage

- Answer the question on bottle use (Block 7 of the FORF, Figure 3-18). Answer *Yes* even if just a few drops were decanted.
- **Return a sample bottle each week whether or not one was used.** This will ensure that sites use only clean sample bottles and that the CAL can account for each sample from the site.

3.3.8.2 General Field Laboratory Analysis

The sample is analyzed only when the sample weight measured in Block 6 is 70 grams or greater. For weights less than 70 grams, it is not necessary to fill out Block 8 (Figure 3-29), and you can proceed to Section 3.3.9, SUPPLIES, Block 9. It has been demonstrated that pH electrode performance improves with use. It is suggested that you calibrate the pH system and measure the Quality Control Check Sample each week, whether or not you have a precipitation sample to measure. If you do this, include the results on the FORF (Block 8) and include the date of the analysis.

8. SAMPLE CHEMISTRY	Specific Conductance (µS/cm)			pH										
Only for buckets with a sample weight of 70 grams or more.	<table border="1" style="display: inline-table; border-collapse: collapse;"> <tr><td style="width: 20px; height: 20px;">7</td><td style="width: 20px; height: 20px;">5</td><td style="width: 20px; height: 20px;">0</td></tr> </table>	7	5	0	÷	<table border="1" style="display: inline-table; border-collapse: collapse;"> <tr><td style="width: 20px; height: 20px;"> </td><td style="width: 20px; height: 20px;"> </td><td style="width: 20px; height: 20px;"> </td></tr> </table>				=	<table border="1" style="display: inline-table; border-collapse: collapse;"> <tr><td style="width: 20px; height: 20px;"> </td><td style="width: 20px; height: 20px;"> </td><td style="width: 20px; height: 20px;"> </td></tr> </table>			
7	5	0												
	Standard Certified		Standard Measured		Correction Factor									
	<table border="1" style="display: inline-table; border-collapse: collapse;"> <tr><td style="width: 20px; height: 20px;"> </td><td style="width: 20px; height: 20px;"> </td><td style="width: 20px; height: 20px;"> </td></tr> </table>				×	<table border="1" style="display: inline-table; border-collapse: collapse;"> <tr><td style="width: 20px; height: 20px;"> </td><td style="width: 20px; height: 20px;"> </td><td style="width: 20px; height: 20px;"> </td></tr> </table>				=	<table border="1" style="display: inline-table; border-collapse: collapse;"> <tr><td style="width: 20px; height: 20px;"> </td><td style="width: 20px; height: 20px;"> </td><td style="width: 20px; height: 20px;"> </td></tr> </table>			
	Correction Factor		Check Sample Measured		Check Sample Corrected									
Is the DI water conductance less than 5 µS/cm?	<table border="1" style="display: inline-table; border-collapse: collapse;"> <tr><td style="width: 20px; height: 20px;"> </td><td style="width: 20px; height: 20px;"> </td><td style="width: 20px; height: 20px;"> </td></tr> </table>				×	<table border="1" style="display: inline-table; border-collapse: collapse;"> <tr><td style="width: 20px; height: 20px;"> </td><td style="width: 20px; height: 20px;"> </td><td style="width: 20px; height: 20px;"> </td></tr> </table>				=	<table border="1" style="display: inline-table; border-collapse: collapse;"> <tr><td style="width: 20px; height: 20px;"> </td><td style="width: 20px; height: 20px;"> </td><td style="width: 20px; height: 20px;"> </td></tr> </table>			
YES <input type="checkbox"/> NO <input type="checkbox"/> (If no, call CAL)	Correction Factor		Precipitation Sample Measured		Precipitation Sample Corrected									
					<table border="1" style="display: inline-table; border-collapse: collapse;"> <tr><td style="width: 20px; height: 20px;"> </td><td style="width: 20px; height: 20px;"> </td><td style="width: 20px; height: 20px;"> </td></tr> </table>									
					Check Sample pH									
					<table border="1" style="display: inline-table; border-collapse: collapse;"> <tr><td style="width: 20px; height: 20px;"> </td><td style="width: 20px; height: 20px;"> </td><td style="width: 20px; height: 20px;"> </td></tr> </table>									
					Precipitation Sample pH									

Figure 3-29. Block 8.

It is generally accepted that under certain conditions, changes in the chemical composition of precipitation occur between the time a sample is collected and its analysis at the CAL. Accurate measurements of both specific conductance and pH at the site are essential to demonstrate and document the occurrence of such changes. Before beginning the detailed procedures described below, it is important to keep in mind the following:

- It is imperative to ship samples to the CAL within 48 hours of their removal from the field.
- Store all solutions at room temperature in a dark place.
- The Quality Control (QC) Check Sample is formulated to approximate a typical precipitation sample. Use Check Sample pH and conductance values to indicate when measurement problems occur.
- If stored properly, all solutions should be usable for up to one year. If at any time you notice contamination or a sudden change in the solution measurements, ask the CAL for a replacement.

**CHANGES TO THE NTN WEEKLY SAMPLING PROCEDURE FOR
DISCONTINUING FIELD CHEMISTRY MEASUREMENTS
STARTING JANUARY 2005**

Insert this page in the NTN Site Operation Manual (July 1999 edition) in front of page 3-25.

1. Remove the sample, transport it back to the lab, weigh and decant from the field bucket into the sample bottle.
2. Follow your weekly routine until you get to section **3.3.8.2 General Field Laboratory Analysis** (page 3-24). Points to highlight in section **3.3.8.2** include:
 - A) Make sure the sample is thawed completely before decanting it into the 1-liter bottle.
 - B) Ship samples to the CAL within 48 hours of their removal from the field.
3. Skip all instructions related to field chemistry measurements (sections **3.3.8.2.1** to **3.3.8.4.6**). Specifically; the steps to ignore (you might want to cross them out in your manual) are:

PAGES	SECTION	TITLE
3-24 to 3-25	3.3.8.2.1	Filling Vials for Field Chemistry Measurements
3-25 to 3-27	3.3.8.3 (.1 to .5)	Conductance Measurement
3-27 to 3-29	3.3.8.4 (.1 to .6)	pH Measurement

3. Continue sample processing with section **3.3.9 SUPPLIES, Block 9**.

REMOVING AN ALIQUOT TO CONDUCT ON-SITE pH AND CONDUCTANCE MEASUREMENTS STARTING JANUARY 2005

Insert this page in the *NTN Site Operation Manual* (July 1999 edition) in front of page 3-25.

1. Volume requirements
 - A) Up to 20 mL may be removed from any sample with a volume greater than 70 mL (>70 grams Sample Weight from Block 6 of the FORF) for on-site field chemistry measurements. The CAL requires at least 50 mL (grams) of sample for complete chemical analysis.
 - B) If you have less than 70 grams of liquid, do not remove any sample from the sample bottle.

NOTE: Sites requiring a larger volume must seek pre-approval from the NADP Program Office.

2. Filling your container
 - A) You must provide your own supplies to remove an aliquot for field chemistry. See supplies list (Appendix page A-3, 12/04) if you intend to continue field chemistry measurements.
 - B) If you have 70 grams of sample or more, pour up to 20 mL from the 1-liter sample bottle into your container.
 - C) Ensure that there is no rim-to-rim contact between the 1-liter sample bottle and your container.
 - D) Do not attempt to replace samples which are spilled in this transfer.

- Shake all solutions prior to use.
- Each Site Operator should be familiar with the manufacturer's instructions for all instruments. The following instructions should not conflict with the manufacturers' instructions for the calibration and operation of the equipment.
- Make sure the sample is thawed completely before decanting it into the sample bottle.
- Before making any measurements, allow all solutions, including the precipitation sample, to reach room temperature.
- If you cannot obtain acceptable values for the pH buffers, specific conductance standard, or QC Check Sample, do not make the field measurements on the actual sample. Instead, call the CAL for assistance.
- Always discard unused portions of any solution. Never return an unused solution to its original container.
- Always determine specific conductance first.
- Distilled water used for rinsing and cleaning should have a specific conductance of less than 2 microsiemens per centimeter ($\mu\text{S}/\text{cm}$). Conductance greater than 5 $\mu\text{S}/\text{cm}$ may result in contamination.
- Space on the FORF is provided for one value of conductivity and one value of pH. If repeat measurements are made, record only one value.
- Appendix B provides additional information that may help in resolving pH and conductivity measurement problems. Indicate these problems on the FORF (Block 10). For further assistance, call the CAL.

3.3.8.2.1 Filling Vials for Field Chemistry Measurements

Rinse and fill four clear 4-mL vials (Figure 3-30) from the sample bottle: two for conductance measurements and two for pH measurements. If the laboratory equipment prevents the use of the 4-mL vials, call the CAL for site-specific instructions about how to proceed.

1. Remove the cap from the sample bottle and place it inside up (top of the cap down) on a clean, disposable laboratory wipe or tissue.

2. *Condition rinse* the vials by filling, discarding, and refilling each one with the sample. Carefully pour the sample avoiding spills and contact with the rim of the sample bottle or the vial.

3. After the vials are filled from the sample bottle, place them in the wooden vial holder provided by the CAL, tightly cap the sample bottle and set it aside.

4. Record the date of the field laboratory analysis on the FORF (Block 8).

5. Until you measure the vials, keep them isolated, protected by the CAL-supplied vial holder cover. Minimize the time between filling the vials and making the measurements.



Figure 3-30. Rinse and fill four vials.

Spilling a little sample during this process is normal. When the *Sample Weight (grams)* is less than 125 (from Block 6), take extra care to avoid losing liquid and do not replace spilled vials.

3.3.8.3 Conductance Measurement

If the conductance cell is not of the recommended low-volume type (see Appendix A), call the CAL for instructions.

3.3.8.3.1 Standardize Meter and Cell

1. Rinse the conductance cell at least three times with distilled water. Rinse once with the 75 $\mu\text{S}/\text{cm}$ standard. Using another portion of standard, measure the specific conductance (Figure 3-31).
2. Record the value obtained in step 1 to the nearest 0.1 $\mu\text{S}/\text{cm}$ in the *Standard Measured* space (see Figure 3-29).
3. Calculate the *Correction Factor* to the nearest 0.001 by dividing the *Standard Certified* (75 $\mu\text{S}/\text{cm}$) by the *Standard Measured* value. Record this value in the spaces provided on the FORF.



Figure 3-31. Measure the conductance standard.

3.3.8.3.2 Measure Conductance of Distilled Water

Rinse the cell three times with distilled water, discarding each rinse. Use a fourth portion to determine the specific conductance of your distilled water. Ideally, the value is less than 2 $\mu\text{S}/\text{cm}$. If the value is 5 $\mu\text{S}/\text{cm}$ or less, check *Yes* in Block 8. If the value exceeds 5 $\mu\text{S}/\text{cm}$, check *No* in Block 8, continue making the conductance measurements, and call the CAL about acquiring a better water source.

3.3.8.3.3 Measure Quality Control Check Sample Conductance

1. Discard and shake off any distilled water from the conductance cell.
2. Next, rinse the cell with the QC Check Sample.
3. Using a second portion, determine the conductance of the Check Sample. Record this value to the nearest 0.1 $\mu\text{S}/\text{cm}$ as *Check Sample Measured* in Block 8.
4. Multiply this value by the *Correction Factor* and record the result as *Check Sample Corrected*. This value should be $14.0 \pm 2.0 \mu\text{S}/\text{cm}$. If the corrected value falls outside these limits, repeat steps 2 and 3. If the corrected value still falls outside these limits, consult Appendix B for corrective action, contact the CAL, and stop the measurements. There is a problem that must be corrected before measurements can resume.

3.3.8.3.4 Measure Precipitation Sample Conductance

1. Rinse the cell three times with distilled water.
2. Rinse it with one of the 4-mL vials of precipitation sample.
3. Use a second 4-mL portion to determine the *Precipitation Sample Measured*. Record this value to the nearest 0.01 $\mu\text{S}/\text{cm}$ and multiply by the *Correction Factor* to obtain the *Precipitation Sample Corrected*.

3.3.8.3.5 Store Conductance Cell

Rinse the cell three times and then fill it with distilled water. Cover the cell to prevent evaporation. Change the storage water weekly even if analyses are not performed. Most but not all cells are stored in distilled water. Always follow the manufacturer's recommendation for the cell.

3.3.8.4 pH Measurement

The CAL supplies all sites with a standard pH electrode. This should be the only electrode used for NTN field pH measurements, and it should be used **exclusively** for NTN samples. Note in Block 9, SUPPLIES, when a replacement electrode is required.

3.3.8.4.1 Prepare pH Meter and Electrode for Testing

1. Adjust the temperature control on the meter to room temperature. If there is no thermometer, set the temperature control to 25°C.
2. Remove the soaker bottle at the tip of the electrode (Figure 3-32). Use a squirt bottle to rinse the electrode tip several seconds in distilled water. Do not allow the squirt bottle tip to touch the electrode.
3. Examine the electrode to make sure any accumulated salts are dissolved from its tip; this build-up occurs during storage. If the accumulation is not dissolved, repeat step 2.
4. Gently blot the electrode tip with a clean lab wipe. Do not rub the electrode as this may build up a static charge and cause erroneous results.



Figure 3-32. Remove the soaker bottle.

5. Remove the black rubber sleeve or tape from the fill hole at the top of the electrode and replenish the filling solution. Use only the filling solution provided by the CAL for the specific electrode.

3.3.8.4.2 Calibrate pH Meter

1. Fill a 4-mL vial with pH 7 buffer.
2. Insert the electrode into the vial (Figure 3-33), and allow it to remain there for 30 seconds. This is called a conditioning rinse of the electrode and vial.

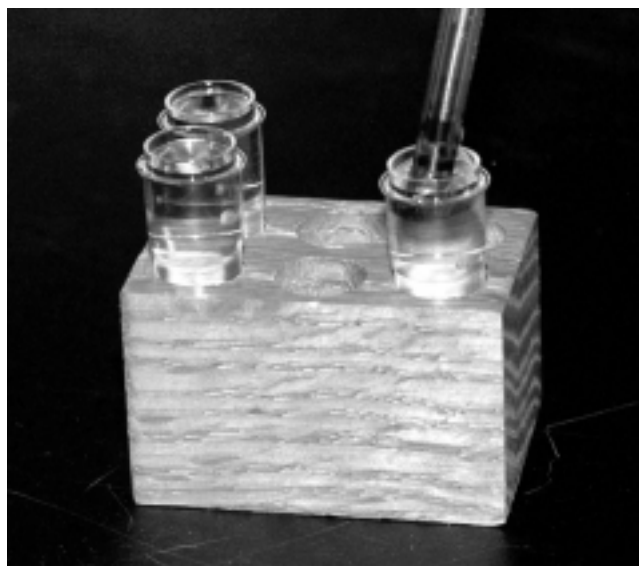

Figure 3-33. Insert the electrode into the vial.

3. Empty the vial and, without any other rinses, refill it with buffer. Insert the electrode tip directly into this condition-rinsed vial and briefly agitate. Allow sufficient time for the reading to stabilize (i.e., until the readings differ by no more than ± 0.02 pH units within a 30-second period), but wait no more than 3 minutes. If the meter has an auto-read function, wait until it *locks on* (1-3 minutes). Adjust the calibration or standardize the control of the meter to read 7.00.
4. Rinse the electrode thoroughly with distilled water and blot the tip. Fill a clean vial with pH 4 buffer. Repeat the conditioning rinse as described in step 2 by inserting the electrode into the vial and allowing it to remain for 30 seconds. Remove the electrode, empty and refill the same vial with the pH 4 buffer, insert the electrode again, and briefly agitate. Allow sufficient time for the reading to stabilize, and then adjust the slope control of the pH meter to read 4.00 or allow the auto-read function to lock on.
5. Rinse the electrode thoroughly with distilled water and blot the tip. Then measure the pH 7 buffer as if it were any other sample. If it reads 7.00 ± 0.03 pH units, proceed with the measurements. If it does not, repeat steps 1 - 4. If you still cannot calibrate the meter, stop the analysis and check Appendix B for possible solutions, or call the CAL for assistance.

3.3.8.4.3 Purge pH Electrode Tip with Distilled Water

Fill a 4-mL vial with distilled water. Condition rinse the tip with distilled water as noted in the steps above. Measure the distilled water, values should be between pH 5.3 and 5.8. **Note:** This step is not meant as a check on the quality of the distilled water. The purpose is to dissolve any high-strength buffer ions from the bulb of the electrode and to get ready for the next measurements of low-strength solutions.

3.3.8.4.4 Measure Quality Control Check Sample pH

1. Gently blot the electrode tip to remove any excess distilled water.
2. Measure the Quality Control Check Sample using the conditioning rinse technique. Briefly agitate the probe and allow the system to stabilize for no more than 3 minutes and record the reading in the space *Check Sample pH* in Block 8. The Check Sample should read 4.90 ± 0.15 pH units.
3. If the measurement is outside this range, recalibrate the meter and try again. If the measurement fails again, consult Appendix B for corrective action, contact the CAL, and stop. This problem has to be corrected before measurements can resume.

3.3.8.4.5 Measure Precipitation Sample pH

1. Rinse the electrode thoroughly with distilled water. Blot the tip.
2. Condition the electrode by inserting it into one of the vials filled with precipitation sample and allow it to remain for 30 seconds.
3. Remove the electrode and reinsert it directly into the second vial containing precipitation. Briefly agitate the electrode and allow the system to stabilize. Record the measured pH value in the space marked *Precipitation Sample pH* in Block 8. **Note:** If you are using a pH meter that locks onto the reading, immediately repeat the measurement. If you obtain the same value, you can be certain the meter has stabilized.

3.3.8.4.6 Store pH Electrode

1. Rinse the electrode thoroughly with distilled water one last time. Blot the tip with a clean absorbent laboratory wipe and place the tip in the soaker bottle.
2. Replace the rubber sleeve or tape over the fill hole to prevent excessive crystal growth.

3.3.9 SUPPLIES, Block 9

The CAL will supply only those items listed in Block 9 of the FORF (Figure 3-34). Requested supplies are added to the returning black mailer from the CAL. **Continue to circle the desired item on each FORF you submit until the item is received.** If you are in danger of running out of a supply, please call your order into the CAL. A *supplies enclosed* sticker will appear on the mailer to alert you. Upon receipt, check each incoming mailer for requested supplies and important notices. Supplies not listed on the FORF, such as distilled water and lab wipes, are the responsibility of the individual site.

9. SUPPLIES	
<i>Circle if needed, until received.</i>	
Vials	Field Forms
pH Electrode	Sample Bottles
pH 4 Buffer	Gloves (S, M, L)
pH 7 Buffer	Raingage Charts
Check Sample	Raingage Ink
75 μ S/cm Std	Dashpot Fluid
Electrode Filling Solution	Lid Seal Pad

Figure 3-34. Block 9.

Request new foam lid seals for the collector by telephone from the CAL. A damaged seal can severely affect sample quality.

3.3.10 REMARKS, Block 10

Block 10 (Figure 3-35) is used to record anything that might affect the representativeness of the weekly sample. This includes equipment failures, repairs, or calibrations; unusual events or weather conditions; contamination; and other occurrences at the field site or field laboratory.

The importance of the information provided in Block 10 cannot be overemphasized.

Careful observations of the sample and the surrounding environment can aid in evaluating sample validity and in data interpretation. Keep in mind that unusual problems or occurrences at or near the site may include plowing, harvesting, burning, increased atmospheric pollution or dust, power outages, etc. Use extra paper if necessary to document all such observations.

10. REMARKS *For example: equipment malfunction, contamination, farming, burning, logging, leakage before weighing, etc.*

Figure 3-35. Block 10.

Also carefully describe all contaminants in the bucket and listed in the notebook when the sample was removed from the field. Remember, this evaluation is especially important because the field bucket contents are not available for CAL personnel to examine.

Finally, note the specific time of the occurrence and circumstances of any leakage or spillage. In particular, note whether the sample leaked before weighing and if this leakage may have compromised the sample volume or quality.

3.4 Mailing Instructions

A large label inside each mailer lid lists the materials to be enclosed with each sample returned to the CAL.

3.4.1 Field Buckets

The following procedures apply to **all** buckets.

1. Remove the snap-on lid and discard any remaining precipitation.
2. Secure the snap-on lid to the bucket.
3. Return the field bucket to the bag used in the field, labeled with the Site ID, date off, etc.

NEW FORF AND SAMPLE BOTTLE BAG BAR CODE LABELS FOR USE STARTING JANUARY 2005

Insert this page in the NTN Site Operation Manual (July 1999 edition) in front of page 3-31.

- 1) Follow your weekly routine until you complete section **3.4.2 Sample Bottles**. To this point you have prepared a 1-liter sample bottle, raingage chart, and a field form (white and yellow copies) for shipping. Keep the pink copy of the field form and a copy of the raingage chart for your records. Label the sample bottle bag as usual.
- 2) Use the labels provided by CAL (see Sample ID Labels figure below). Two labels are provided for each sample. **Start with the first set (indicated in green on the Sample ID Labels figure below)**. Place one label over Block 1 of the white copy of the field form and the identical label on the outside of the bottle bag (see figure at bottom). Use the labels in ascending order for each sample you submit to CAL.
NOTE: continue to write your Site ID on Block 1 SITE of the FORF as normal.



Sample ID Labels

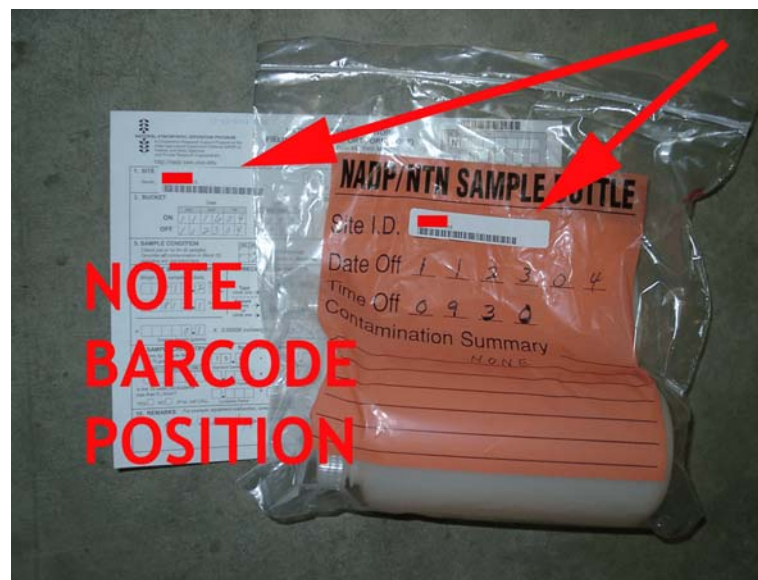

Preferred Bar Code Position

4. Use a twist tie to secure the top of the bag.
5. Place the bagged field bucket into the mailer. Return all used buckets, lids, and bottles to the CAL for cleaning.

3.4.2 Sample Bottles

Always return a sample bottle in a labeled bag to the CAL each week. The following procedures apply to **all** bottles:

1. Check the bag labeling. Make sure all notes and comments are legible and can be understood. Write the Site ID, date and time off, and a brief description of any contamination on the bag.
2. Dry the outside of the sample bottle with a laboratory wipe.
3. Place the sample bottle into the bag, close the bag completely, and press out any trapped air.
4. Place the bagged sample bottle into one corner of the mailer.

3.4.3 Final Items

1. Enclose the white and yellow copies of the completed FORF and the original raingage chart in the black mailer. The pink copy of the FORF is for site records. Also keep a copy of the raingage chart.

2. Turn over the pre-addressed mailing card on the black mailer so that the CAL address shows (Figure 3-36).

3. Place the lid on the mailer and secure all four straps tightly.

4. Send the black mailer immediately by UPS regular delivery, Federal Express, or first class mail.

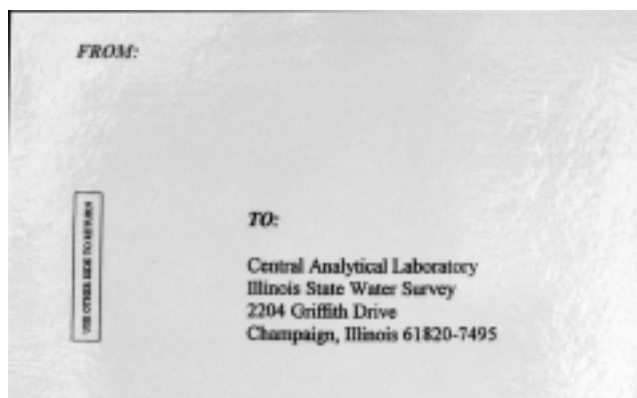

Figure 3-36. Make sure the CAL address shows.

Send buckets and bottles no later than 48 hours after the sample has been removed from the field. Extended delays can invalidate samples.

3.5 Recordkeeping at the Site

It is suggested that Site Operators keep the pink copies of the FORF stapled to copies of the raingage charts and filed in chronological order. Questions will arise during the processing of the samples at the CAL and after receipt of the data reports from the CAL (See Section 4). Your data will help resolve questions and correct data errors.

Any notebooks taken to the field or used in the laboratory should be preserved for future use.

Retain site records for 2 years after submission of samples.

4 Preliminary Data Printouts

Each month the CAL sends Site Operators and Supervisors two reports that contain data from the FORFs and preliminary chemical analyses from the CAL. These reports contain messages that address potential errors or inconsistencies noted during the initial CAL data review.

Site Operators and Supervisors are expected to review and respond to messages on printouts by forwarding corrections, explanations, or clarifications to the CAL. Data in these reports are preliminary and not for research. Final screened and verified data are available at the NADP Web site at <http://nadp.sws.uiuc.edu> or by contacting the Program Office.

4.1 Report Headings

The PRINTOUT DATE, SAMPLE ID, LAB TYPE and DATE/TIME are the same on the field (Figure 4-1) and preliminary (Figure 4-2) printouts.

PRINTOUT DATE: The date the report was generated appears in the upper left corner.

SAMPLE ID: A unique 12-character code assigned at the CAL identifies each sample. The first letter *N* identifies this as an NTN sample. Characters in positions 2-6 indicate a sequential number. Character 7 (normally an *S*) is used to identify a standard sample. Character 8, a *W*, denotes a wet-side sample. Characters in positions 9-12 identify the site ID.

LAB TYPE: A code assigned by the CAL indicates the type of laboratory processing the sample received. The first letter (i.e., *T*, *W*, or *D*) indicates the amount of liquid observed in the 1-liter sample bottle at the CAL. The second letter is *A*, which indicates 50 mL of dilution water was added to provide a complete chemical analysis, or *F*, which denotes a USGS field blank sample. Codes used are as follows:

- *T*: The sample bottle contained a trace of water possibly allowing a pH measurement, or pH and conductivity measurements. The volume was insufficient for additional chemical measurements.
- *W*: The sample bottle contained 35 mL or more of water. All chemical analyses were performed without any need for dilution.
- *WA*: The sample bottle contained less than 35 mL of water. After pH and conductivity were measured, 50 mL of dilution water was added to provide adequate sample for the 9 other analyses. All concentrations in the reports are corrected for dilution.
- *D*: No water was visible in the sample bottle or wet-side bucket upon arrival at the CAL. No chemical analysis was performed.
- *DF*: This Lab Type denotes a USGS *Field Blank* sample (See Section 6.5).

DATE ON/ TIME ON AND DATE OFF/TIME OFF: Local times identify the sampling period.

4.2 CAL Field Printout

The Field Printout (Figure 4-1) provides the site personnel with information from the FORF. It also lists the CAL pH and conductance values and evidence of sample leakage. Notes and error messages alert the Operator and Supervisor to potential data or operational problems. A key to the report headings, and list of the notes and error messages follows.

FIELD CHEM DATE: This date indicates when the Site Operator performed the field chemistry measurements.

PH/ LAB - FLD: These are the CAL (LAB) and the Site Operator (FLD) pH measurements.

CONDUCTIVITY/ LAB - FLD: These are the CAL (LAB) and the Site Operator (FLD) conductance measurements.

SAMPLE VOLUME (ML): This number indicates the water volume in the bucket when it was removed from the collector, as calculated in Block 6 of the FORF.

SAMPLE DEPTH (IN.): This is the SAMPLE VOLUME converted into inches of precipitation as in Block 7 of the FORF.

PRECIP. DEPTH (IN.): This number is the total sampling period precipitation from the raingage in inches.

LEAKAGE: This column describes the amount of water observed in the plastic bag enclosing the sample bottle when it was opened at the CAL.

Notes and Error Messages

Note and error messages are generated by computer programs that check for data errors, non-standard procedures, and potential field chemistry, collector, or raingage problems. Only those notes and error messages pertaining to field operations are listed here.

(→) AN ARROW PRECEDING A NOTE DENOTES A RESPONSE IS REQUIRED

*
ASAP** ERROR 1 - TIME ON for sample ____ (SAMPLE ID ASSIGNED BY CAL) precedes the TIME OFF for
RESPOND*** SAMPLE ____ (SAMPLE ID ASSIGNED BY CAL). PLEASE NOTIFY CAL OF CORRECT TIMES BY
ASAP** SENDING A NOTE WITH YOUR NEXT BUCKET MAILING....THANKS.
*

*
** NOTE 2 - Time between sample ____ (SAMPLE ID ASSIGNED BY CAL) off and sample ____
***** (SAMPLE ID ASSIGNED BY CAL) on is more than 59 minutes ____ (CALCULATED VALUE). POSSIBLE
** MISSING SAMPLE(S).
*

NOTE 3 - The sampling interval for ____ (SAMPLE ID ASSIGNED BY CAL) was nonstandard.
The interval was ____ (CALCULATED VALUE) days.

NADP/NTN CENTRAL ANALYTICAL LABORATORY - ILLINOIS STATE WATER SURVEY

FIELD PRINTOUT

PRINTOUT DATE: 06/15/1999

QUESTIONS, CALL Scott Dossett (800-952-7353)

PLEASE NOTE - DATA WITH A SAMPLE ID LESS THAN NS6401SW (MARKED WITH AN ASTERISK) HAS BEEN REVIEWED BY THE CAL FOR THIS REPORT

SAMPLE ID	TYPE	LAB DATE ON	TIME ON	DATE OFF	TIME OFF	FIELD		CONDUCTIVITY		SAMPLE VOLUME	SAMPLE DEPTH	PRECIP. DEPTH	LEAKAGE
						CHEM DATE	PH LAB FLD	LAB	FLD	(ML)	(IN.)	(IN.)	
*NS6270SWIL11	W	033099	0930	040699	0930	040699	6.52 5.23	50.8	48.3	346.0	.20	.51	NONE
NS6517SWIL11	W	040699	0930	041399	0930	041399	4.77 4.61	18.8	22.2	1680.1	.97	1.02	NONE
NS6720SWIL11	W	041399	0930	042099	0930	042099	4.46 4.35	19.7	21.5	3170.3	1.84	2.10	NONE
NS6969SWIL11	W	042099	0930	042799	0935	042799	4.52 4.45	23.0	24.1	1351.9	.78	.76	NONE
NS7174SWIL11	W	042799	0935	050499	0930	050499	4.18 4.11	35.2	38.6	652.3	.38	.36	NONE

NOTE 6 - The LAB pH differed by more than 1.0 pH units from the FIELD pH for sample *NS6270SWIL11.

NOTE 9 - The SAMPLE DEPTH of *NS6270SWIL11 does not compare well with the PRECIPITATION DEPTH recorded for that period. If you have not yet done so, please send the CAL any information you have that might explain this difference...THANKS

PLEASE REVIEW THIS INFORMATION AND RESPOND TO NOTES AND ERRORS.

FIRST, CHECK YOUR PINK FIELD FORM COPIES.

THEN, WRITE A SHORT RESPONSE ON THIS PRINTOUT AND RETURN IT (OR A COPY) TO THE CAL WITH YOUR NEXT SAMPLE.

OUR DATA REPORTS OVERLAP AND SOME NOTES MAY BE REDUNDANT. PLEASE BE PATIENT.

CALL SCOTT DOSSETT AT 800-952-7353, FAX TO 217-333-0249 OR E-MAIL TO SDOSSETT@UIUC.EDU WITH QUESTIONS OR COMMENTS.

THANK YOU FOR YOUR CONTINUED COOPERATION.

THE 20 US/CM AND 1.0 PH UNIT CRITERIA USED TO TRIGGER PH AND CONDUCTIVITY NOTES ARE ARBITRARY CHOICES, AND MAY OR MAY NOT INDICATE MEASUREMENT PROBLEMS.

Figure 4-1. CAL field printout.

NOTE 4 - ____ (SAMPLE ID ASSIGNED BY CAL) did not have a standard TUE-TUE sampling period. Actual sampling period was ____ (FROM FORF).

NOTE 5 - The FIELD pH for sample ____ (SAMPLE ID ASSIGNED BY CAL) ____ (FROM FORF) was outside the expected range for precipitation samples ____ (expected range is 3.0 to 9.0).

NOTE 6 - The LAB pH differed by more than 1.0 pH units from the FIELD pH for sample ____ (SAMPLE ID ASSIGNED BY CAL).

NOTE 7 - The FIELD CONDUCTIVITY for sample ____ (SAMPLE ID ASSIGNED BY CAL) ____ (FROM FORF) was outside the expected range for precipitation samples ____ (expected range is 1.0 to 300.0).

NOTE 8 - The LAB CONDUCTIVITY differed by more than 20 uS/CM from the FIELD CONDUCTIVITY for sample ____ (SAMPLE ID ASSIGNED BY CAL).

NOTE 9 - The SAMPLE DEPTH of (SAMPLE ID ASSIGNED BY CAL) does not compare well with the PRECIPITATION DEPTH recorded for that period. If you have not yet done so, please send the CAL any information you have that might explain this difference....THANKS.

NOTE 10 - Sample ____ (SAMPLE ID ASSIGNED BY CAL) had major LEAKAGE during shipment to the CAL.

*

ASAP** ERROR 11 - A required DATE or TIME for sample ____ (SAMPLE ID ASSIGNED BY CAL) is
RESPOND*** missing. Please notify the CAL of missing info by sending a note with
ASAP** your next bucket mailing....THANKS.

*

NOTE 12 - Sample ____ (SAMPLE ID ASSIGNED BY CAL) was not bagged. PLEASE BAG ALL BUCKETS BEFORE SHIPMENT TO THE CAL.

NOTE 15 - At the CAL it was noticed that the lid was not completely secured to the bucket for sample ____ (SAMPLE ID ASSIGNED BY CAL). PLEASE BE SURE TO SNAP THE LID ON ALL BUCKETS SENT TO THE CAL.

NOTE 16 - This sample ____ (SAMPLE ID ASSIGNED BY CAL) was compromised by problems during field handling or shipping. THE DATA WILL BE FLAGGED AS NONSTANDARD.

NOTE 19 - For sample ____ (SAMPLE ID ASSIGNED BY CAL) more than 16 days elapsed between the DATE OFF and the date the sample arrived at the CAL. Please ship all samples within 48 hours of collection....THANK YOU.

*

ASAP** ERROR 20 - A pH or conductivity measurement was reported for sample ____
RESPOND*** (SAMPLE ID ASSIGNED BY CAL) but the FIELD CHEM DATE IS MISSING. Please notify the CAL
ASAP** of the missing info by sending a note with your next sample
* or calling Scott....THANKS.

*

ASAP** ERROR 21 - For sample ____ (SAMPLE ID ASSIGNED BY CAL) the DATE OFF, FIELD CHEM DATE, and
RESPOND*** CAL receipt dates are not in chronological order. Please re-check
ASAP** your DATE OFF and FIELD CHEM DATE and send corrected date(s) to the CAL.
*

NOTE 25 - For over half of the samples in this report, the SAMPLE DEPTH ____ (from AEROCHEM COLLECTOR) is greater than the PRECIP DEPTH ____ (from RAINGAGE). Your recording raingage appears to be undercatching. Please refer to your INSTRUCTION MANUAL, Appendix D for calibration check procedures.

PLEASE REVIEW THIS INFORMATION AND RESPOND TO NOTES AND ERRORS.

FIRST, CHECK YOUR PINK FIELD FORM COPIES.

THEN, WRITE A SHORT RESPONSE ON THIS PRINTOUT AND RETURN IT (OR A COPY) TO THE CAL WITH YOUR NEXT SAMPLE.

OUR DATA REPORTS OVERLAP AND SOME NOTES MAY BE REDUNDANT. PLEASE BE PATIENT.

CALL SCOTT DOSSETT AT 800-952-7353, FAX TO 217-333-0249 OR E-MAIL TO SDOSSETT@UIUC.EDU WITH QUESTIONS OR COMMENTS.

THANK YOU FOR YOUR CONTINUED COOPERATION.

THE 20 μ S/CM AND 1.0 PH UNIT CRITERIA USED TO TRIGGER PH AND CONDUCTIVITY NOTES ARE ARBITRARY CHOICES, AND MAY OR MAY NOT INDICATE MEASUREMENT PROBLEMS.

4.3 CAL Preliminary Printout

The preliminary printout (Figure 4-2) provides site personnel with data that are still undergoing verification. As part of this process, some samples are reanalysed. Additional screening of these data may result in their sequester from the final network database. A key to the report follows.

CONCENTRATIONS (MG/L): Preliminary analytical measurements are reported for each chemical in concentration units of milligrams per liter of solution. The chemicals measured include calcium (CA), magnesium (MG), potassium (K), sodium (NA), ammonium (NH₄), nitrate (NO₃), chloride (CL), sulfate (SO₄), and orthophosphate (PO₄). For samples with a LAB TYPE of W or WA, a full set of chemical concentrations is reported. For samples with a LAB TYPE of T, only pH and conductivity measurements are possible due to the small sample size. For samples with a LAB TYPE of D or DF, the ion concentrations will always be missing. All measured concentrations at or below the analytical method detection limit (very dilute solutions) are reported with a less than symbol (e.g., < .003 mg/L).

FIELD/LAB - COND.: These are Site Operator (FIELD) and CAL (LAB) conductance measurements.

FIELD/LAB - pH: These are Site Operator (FIELD) and CAL (LAB) pH measurements.

DEPOSITION (MILLIGRAMS/SQUARE METER): This lists the mass of each chemical deposited on a square meter by the precipitation in each sample. Chemical deposition is calculated from the product of the SAMPLE VOL and CONCENTRATION measurements divided by the cross-sectional area of the collection bucket, which is 0.0679 square meters. If the CONCENTRATION is below the analytical method detection limit, the calculation uses this value and the DEPOSITION is reported with the less than symbol.

SAMPLE VOL (ML): This is the water volume in the field bucket when it was removed from the collector, as calculated in Block 6 of the FORF.

MEAS ANIONS/ MEAS CATIONS (MICROEQUIV/L): The respective sums of the measured anion and cation concentrations are converted to charge units of microequivalents per liter. The conversion from milligram per liter (MG/L) to microequivalent per liter (MICROEQUIV/L) is done using these factors:

<i>Anions</i>	<i>Factor</i>	<i>Cations</i>	<i>Factor</i>
SO ₄	20.83	NH ₄	55.44
NO ₃	16.13	CA	49.90
CL	28.21	MG	82.26
PO ₄	31.59	K	25.57
		NA	43.50
		H	(10 ^{6-lab pH}) Example: lab pH = 4
			H = 10 ² or 100 MICROEQUIV/L

PRELIMINARY PRINTOUT NADP/NTN CENTRAL ANALYTICAL LABORATORY - ILLINOIS STATE WATER SURVEY
 DATE: 06/15/99

PLEASE NOTE - DATA WITH A SAMPLE ID LESS THAN NS6401SW (MARKED WITH AN ASTERISK) HAS BEEN REVIEWED BY THE CAL FOR THIS REPORT

SAMPLE ID	LAB TYPE	DATE ON	TIME ON	DATE OFF	TIME OFF	CA	MG	K	CONCENTRATIONS (MG/L)						FIELD COND.	LAB COND.	FIELD PH	LAB PH
									NA	NH4	NO3	CL	SO4	PO4	(MICROMHOS/CM)			
*NS6270SWIL11 W		033099	0930	040699	0930	1.082	.152	1.060	.280	5.19	4.10	.57	7.48	3.302	48.3	50.8	5.23	6.52
NS6517SWIL11 W		040699	0930	041399	0930	.308	.085	.058	.217	.52	2.11	.22	2.74	<.003	22.2	18.8	4.61	4.77
NS6720SWIL11 W		041399	0930	042099	0930	.087	.012	.008	.009	.27	1.48	.04	1.66	<.003	21.5	19.7	4.35	4.46
NS6969SWIL11 W		042099	0930	042799	0935	.361	.045	.045	.108	.67	2.33	.16	2.40	<.003	24.1	23.0	4.45	4.52
NS7174SWIL11 W		042799	0935	050499	0930	.066	.013	.018	.011	.29	2.06	.07	2.93	<.003	38.6	35.2	4.11	4.18

SAMPLE ID	LAB TYPE	CA	DEPOSITION(MILLIGRAMS/SQUARE METER)						CL	SO4	PO4	SAMPLE H VOL(ML)	MEAS ANIONS	MEAS CATIONS
			MG	K	NA	NH4	NO3	(MICROEQUIV/L)						
NS6270SWIL11 W		5.51	.77	5.40	1.43	26.45	20.90	2.91	38.12	16.83	.00	346.0	342.3	393.8
NS6517SWIL11 W		7.62	2.10	1.44	5.37	12.87	52.22	5.44	67.81	<.07	.42	1680.1	97.4	79.1
NS6720SWIL11 W		4.06	.56	.37	.42	12.61	69.12	1.87	77.52	<.14	1.63	3170.3	59.6	55.6
NS6969SWIL11 W		7.19	.90	.90	2.15	13.34	46.40	3.19	47.79	<.06	.61	1351.9	92.1	94.9
NS7174SWIL11 W		.63	.12	.17	.11	2.79	19.79	.67	28.15	<.03	.64	652.3	96.3	87.4

MONTHLY NEWS AND NOTES

Figure 4-2. CAL preliminary printout.

4.4 Monthly News and Notes

Each month news items or notes appear in the lower portion of the Preliminary Printout. Occasionally these include some “fill-in the blank” questions (e.g., to request updates to FAX numbers). Please complete these and return a copy to the CAL in these cases. Other news or notes do not require a response.

4.5 Usage Reminder

This report is for Site Supervisors and Operators use only. Remember, these preliminary data are subject to change. Final data are available on the NADP Web site at <http://nadp.sws.uiuc.edu>.

5 Field Site Maintenance

NTN sites are positioned and equipped according to site selection and installation rules that apply to the entire network. Occasionally you will need to perform maintenance tasks in order for the site to continue to meet these rules and collect high-quality data. These tasks are divided into two general categories:

- immediate site area maintenance
- field site equipment maintenance

Before making **any modifications** to the field site or equipment, or if you have questions about maintenance, PLEASE call the NADP Program Office at 1-800-952-7353.

5.1 Immediate Site Area Maintenance

Figure 5-1 is an idealized site diagram that serves as a handy reference regarding the rules for equipment spacing, vegetation height, and proximity of roads and buildings. Maintaining the height

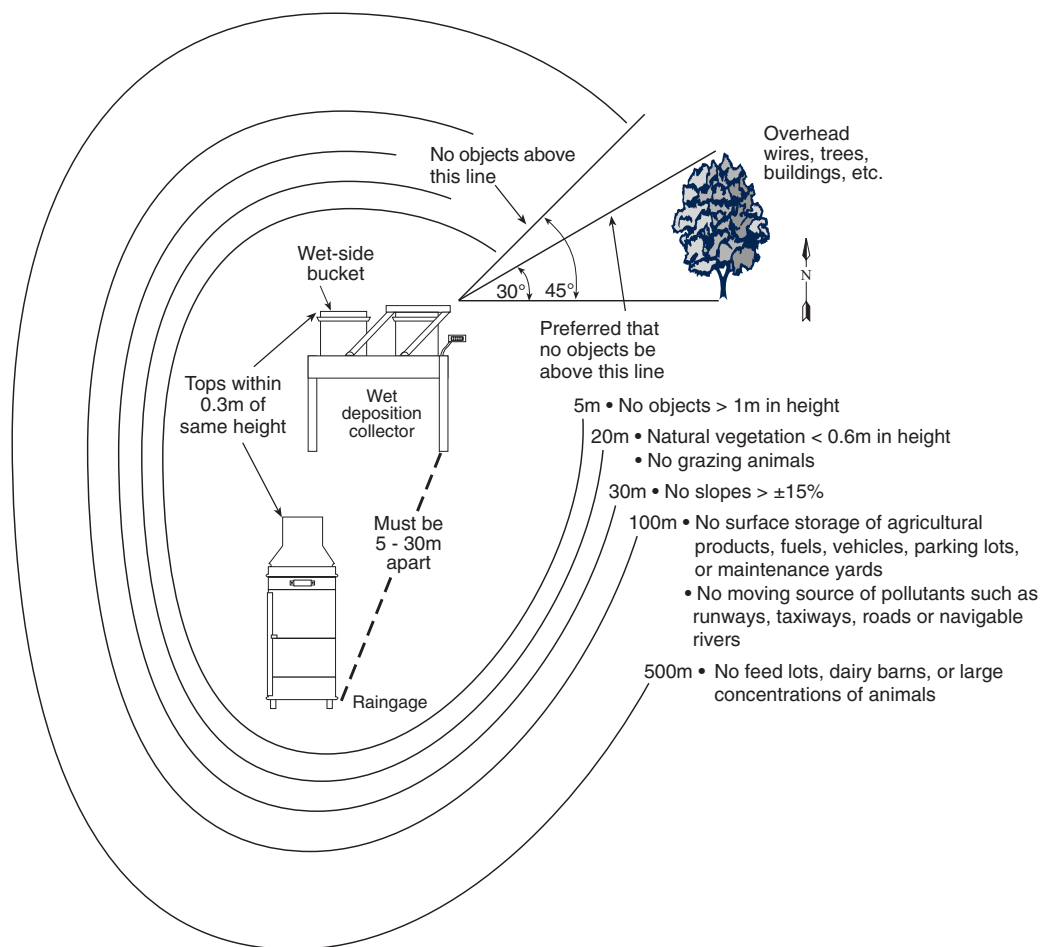

Figure 5-1. An idealized site.

of vegetation at the site is the responsibility of site personnel. The NADP Program Office should be informed of changes in the location, size, or character of other site attributes.

5.1.1 Vegetation Maintenance

For site maintenance, consider everything within 30 meters (m) of the collector and raingage. Leaves, grass seeds, or debris from nearby shrubs and trees can contaminate samples. The rules for maintaining vegetation are:

- Maintain annual vegetation on site at heights of less than 0.6 m. **Sites should not be mowed solely for aesthetics. Debris generated by frequent mowing may get into the sample bucket. Two or three mowings per year are adequate as long as the 0.6 m height requirement is met.**
- Ground cover should surround the collector and raingage for about 30 m. In areas where there are agricultural crops, a vegetated buffer strip **must** surround the collector for at least 30 m.

5.1.2 Obstructions in Wind Field

Immediate site area maintenance focuses on preventing contamination of the wet-side sample. These concerns for sample *quality* (i.e., the concentration of chemicals in samples) must be accompanied by concerns for sample *quantity* (i.e., representative precipitation amounts). To this end, criteria describing potential wind field obstructions apply. These obstructions may result in splash from one piece of equipment to another or cause one instrument's collection to be impeded by another. Relevant criteria are:

- No object over 1 m high with sufficient mass to deflect wind should be within 5 m of the collector or raingage.
- The height of any obstruction defines the minimum distance between the collector or raingage and the obstruction; doubling this distance is preferable. No object (such as equipment towers or trees) should project onto the collector or raingage with an angle greater than 45°; 30° is optimal.

See the *Instruction Manual: NADP/NTN Site Selection and Installation* (NADP, 1984) for complete details regarding network siting criteria.

5.2 Field Site Equipment Maintenance

5.2.1 Aerochem Metrics 301 Precipitation Collector (see also Appendix C)

5.2.1.1 Sensor and Motor Box Checks

Each week, test the collector to confirm that a) the sensor heater is fully operational and b) it responds to precipitation and the motor box drives the lid to the correct position. These tests are made as follows:

1. Check the sensor temperature by touching the sensor plate. It should feel cool, unless the collector has been open within the last few minutes.

2. Activate the sensor grid by applying a few drops of water. **Do not use metal.**
3. The drive motor should immediately move the collector lid to cover the dry-side bucket. Observe this movement. The collector lid should operate freely with little motor noise and come to rest snugly on the dry-side bucket.
4. Check the motor box operation by inspecting the recording raingage while the collector is open (i.e., wet-side bucket exposed). Verify that the event recorder (upper) pen is in the up position.
5. After the collector has been open for 5-10 minutes, confirm that the sensor is hot to the touch.
6. Blow any remaining water off the sensor and observe the collector lid movement as it covers the wet-side bucket. It should move smoothly and complete its cycle in less than 15 seconds.

5.2.1.2 Sensor Head Cleaning

Periodically clean the sensor to remove any debris that could cause the collector to open and leave the wet-side bucket exposed during dry periods.

With the wet-side bucket removed and the collector plugged in:

1. Irrigate the sensor with distilled water or alcohol. (The collector will open. Just ignore this.)
2. Using a toothbrush, gently scrub the area between the sensor grid and plate. Avoid bending the grid and leave no brush residue trapped in the sensor.
3. Again, irrigate the sensor to rinse away any loosened residue.
4. Blow any remaining liquid off the sensor to allow the collector lid to return to the wet-side position.

5.2.1.3 Dry-Side Changes, Lid Seal Cleaning and Replacement

On the first Tuesday of every month, change the dry-side bucket and clean the underside of the lid seal. Use a clean, lint-free tissue dampened with distilled water. Wipe loose dirt from the lid surfaces. This limits any excess build-up of contaminants. Allow the lid seal to air dry (See Section 3.2.3 for detailed instructions).

Approximately every 12 months the CAL provides each site with a new foam lid seal and instructions for its installation (Figure 5-2). This replacement further limits contamination and helps ensure a tight lid-to-bucket seal. To change the lid seal, use a medium-sized straight blade screwdriver and follow these steps:

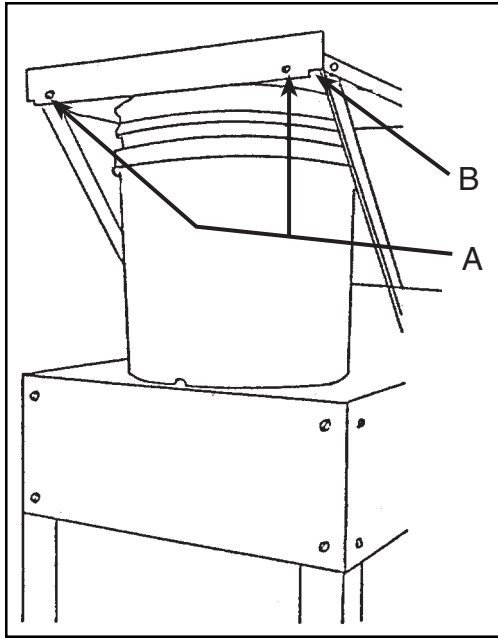

Figure 5-2. Removing the lid seal.

1. First, remove both buckets from the aluminum bucket holders. Position the lid mid-stride by unplugging the collector as the lid approaches the mid-point between the bucket holders.
2. Next, remove the two screws labeled A on Figure 5-2 and the L-retainers they hold in place. These retainers, labeled B, hold the foam lid seal in place. After removing the L-retainers, the old seal will simply drop out. Be careful not to lose the screws.
3. Insert the new foam lid seal and re-install the L-retainers and screws. This completes the lid seal change.
4. Plug the collector back into its power supply.
5. Record the lid seal change in Block 10 of the FORF.

5.2.1.4 Winter Operation

Depending on the site location, winter operation may pose a serious problem for collecting wet-deposition-only samples and may severely stress the operating components of the collector. Some of the more common problems encountered during winter operation are:

- The collector lid seal freezes to one of the buckets.
- The collector lid becomes immobilized due to accumulation of heavy snow or ice.
- The collector does not detect light blowing snow.
- Winds blow snow from an open wet-side bucket.

Typical symptoms of the above problems include:

- Total raingage depth indicates much more precipitation than the sample depth.
- Event recorder trace does not indicate the correct number or duration of events.
- Dry-side bucket contains snow and ice.
- Collector clutches are worn and motor units are burned out.

If any of these problems are regular occurrences, then the collector may need to be modified (although there is a limit to how much wintertime performance can be improved). Consider investments in optional equipment such as a peaked snow roof and/or heated lid seal pad, or an enclosed and heated collector base. **Consult the CAL prior to purchase or installation of any of these options.** Once installed, these devices remain on the collector through all seasons as a permanent modification. Under no circumstances should the foam lid seal be removed to alleviate problems.

The quality of samples affected by winter problems may be very difficult to assess. Note the condition of the equipment as you first saw it, the symptoms of any failure, and especially the extent to which the wet-side sample may have been affected in FORF Block 10, Remarks.

5.2.2 Belfort B5-780 Recording Raingage (see also Appendix D)

5.2.2.1 Winter Operation

The most common difficulties with the raingage during the winter are:

- Cold-induced clock problems
- Blowing snow-related problems

Chart clocks do not function well when the ambient temperature drops below 20° to 25°F. The wind-up raingage clock may not be able to run the full 7 days required. For sites at high altitudes or otherwise limited access or sites experiencing extremely cold conditions, a battery-powered clock (available from the manufacturer) is suggested. This type of clock operates on two C-cell batteries and is not as sensitive to cold temperatures as the wind-up clock.

Blowing snow poses a significant problem in the winter operation of the raingage. Besides the inaccurate measurement of precipitation caused by snow blowing out of the gage, the dashpot and internal mechanism of the raingage may be damaged if snow enters the housing. To prevent these problems, the network requires sites to winterize raingages.

Winterization Instructions

- Remove the funnel attached to the bottom of the top cap by rotating the funnel until its slots clear the beads in the collector tube (see Appendix D). Lift it off and store it in a safe place.
- Empty the catch bucket, replace it in the gage, and add 2 quarts of standard automotive ethylene glycol or propylene glycol antifreeze. This addition will cause the gage to read the equivalent of 2.75 inches of precipitation.
- **Do not make any zeroing adjustment to the gage baseline after adding antifreeze to the bucket.**
- Stir the antifreeze solution in the bucket each week after moving the recording pens away from the raingage chart drum.

Do not dump any antifreeze on the ground. It is toxic to plants and animals. Disposal of antifreeze should comply with proper disposal guidelines.

Table 5-1 gives the approximate freezing temperatures of the antifreeze solution when diluted by precipitation to the raingage reading indicated. Empty the catch bucket and recharge the antifreeze whenever the gage level and the prevailing temperatures indicate that freezing is probable.

Table 5-1. Catch Bucket Freezing Temperature

Gage Reading, inches	5	6.5	7.5	12
Freezing Temperature, °C	-37	-24	-18	-9

- Snow or mixed precipitation amounts are invalidated when the raingage is not properly winterized.
- The CAL notifies sites each winter about winterization procedures. The notice serves as a reminder of the importance of raingage winterization. Unfortunately, the notice may come too early for some sites and too late for others. Sites in northern regions should not wait for the memo. Each Site Operator is responsible for implementing the winterization procedure when temperatures begin to drop below freezing (32°F). For some high-elevation sites, year-round winterization is necessary, because snow, sleet, or freezing rain can occur at any time.

5.2.2.2 Calibration, Turnover, and Sensitivity Checks

5.2.2.2.1 Calibration

Check the raingage calibration at least twice a year and whenever inconsistencies between the Sample Depth and Total Raingage Depth become frequent. This comparison, made while filling out Block 7 (Precipitation Record) of the FORF, is very important (see Section 3.3.7.3 for detailed instructions). Of particular concern are periods when the Total Raingage Depth is less than the Sample Depth because this indicates the collector is catching more precipitation than the raingage. This is the reverse of the normal situation when the collector is expected to miss some precipitation before opening, thus resulting in smaller volumes than the raingage.

Please report the results of this check in FORF Block 10, Remarks, and call the CAL at 1-800-952-7353. When this check indicates a calibration problem, you may be advised to take corrective actions up to replacing your raingage with a rebuilt one from the CAL.

Raingage calibration is based on the knowledge that 825 grams causes the precipitation pen to rise 1 inch on the raingage chart. Complete calibration instructions are available in Appendix D.

To check raingage calibration, follow these steps:

1. Place a test chart onto the chart drum and install it in the raingage. (see Section 3.2.5 for detailed instructions on changing the raingage chart.)
2. Start the pen inking by moving the pen up and down and then slightly rotating the drum.
3. Add six 825 gram objects one at a time to the bucket, each time turning the drum slightly so as to form a “stairstep” pattern on the test chart.
4. Repeat Step 3. This time **remove** the weights one by one.

5. Evaluate the calibration check by reading “rainfall amount” at each step of the weight additions and subtractions. Each step should be 1 inch up or down from the previous step. If all are within 0.10 inches of the target value, they are ok. If not, call the CAL.
6. Send a photocopy of the test chart to the CAL.

5.2.2.2.2 Turnover Check

This check affirms that the dual traverse gage will move to the 6-inch level, reverse its direction, and continue down the chart to measure a maximum of 12 inches of precipitation. In addition, this test confirms that the precipitation pen and the event recorder pen have adequate clearance.

The check entails gently pushing down on the catch bucket. The precipitation pen and the event marker pen should pass each other without touching at about the 5.5-inch level. Subsequently, the precipitation pen reverses direction. This reversal or turnover point should occur ± 0.10 inches from the top of the chart at the 6.0-inch line. If turnover is outside this range or is impeded by the event recorder pen, call the CAL.

5.2.2.2.3 Sensitivity Check

In order to accurately characterize the precipitation at your site, the raingage should respond or be sensitive to even very small additions, i.e., small amounts of precipitation. To check gage sensitivity, gently tap the inside of the catch bucket with one finger and observe the precipitation pen. A quick response from the pen should be observed. Call the CAL if the gage fails this simple test. It may be corroded or dirty.

5.3 Replacement of Field Equipment Components

The CAL provides all field replaceable components for both the Aerochem Metrics collector and the Belfort recording raingage. These components include the collector sensor, motor box, raingage clock, event recorder, and tower mechanism. All components are shipped via 2nd day delivery with detailed instructions regarding the tools required, component removal and installation, packing, and return shipping. Appendices C and D also detail component replacement procedures. Refer all equipment problems or questions to the CAL at 1-800-952-7353.

5.4 Power Requirements for Field Site Operation

The precipitation collector will operate from either 110V AC line current or 12V DC battery power. In addition, the collector can be set up to operate from 110V AC power; when this line voltage is lost, the 12V DC battery takes over. Note that the recording raingage does not require either power source. The collector motor box provides the power to operate the event recorder, and the raingage clock is powered by either wind-up or C-cell batteries.

5.4.1 110 Volt AC Line Power

This is the most reliable way to operate the site. The collector consumes very little power, a supply with a 15 amp rated duplex is adequate. If power outages are a problem, it is recommended that the site install a DC back-up battery. Call the CAL for battery specifics. The network recommends installation of a Ground Fault Interrupt (GFI) circuit breaker outlet. The GFI (which is commonly used around domestic water supplies) senses imbalances in the 110V AC line and shuts off the power very quickly, an excellent safety feature.

5.4.2 12 Volt DC Power

The collector can operate from either a DC/solar-assisted system or a DC battery. Because of problems encountered during winter, the hazards of transporting batteries, and the difficulty troubleshooting weak DC systems, it is recommended that the site not be operated solely off battery power. The requirements for solar panel sizing and battery storage capacity are discussed in the *Instruction Manual: NADP/NTN Site Selection and Installation*. Figure 5-3 is an idealized drawing of the typical DC/solar power system.

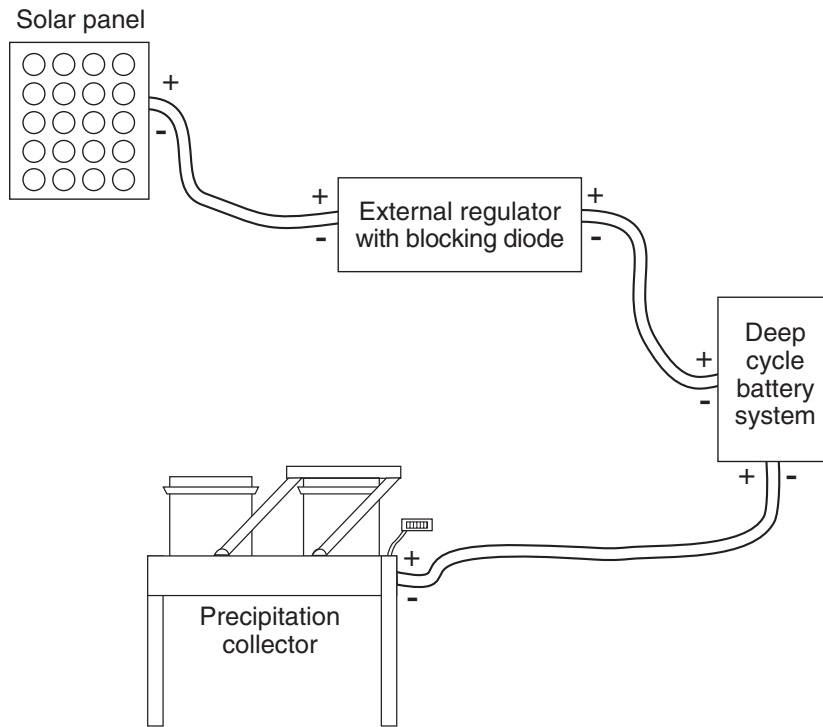

Figure 5-3. An idealized DC solar system.

5.5 References

NADP. 1984. *Instruction Manual: NADP/NTN Site Selection and Installation*, NADP Program Office, Champaign, IL.

NADP. 1990. *Quality Assurance Plan: NADP/NTN Deposition Monitoring*. NADP Program Office, Champaign, IL.

6 Quality Assurance Programs

Periodically, sites are required to participate in NTN quality assurance programs supported by the U.S. Geological Survey (USGS) and the U.S. Environmental Protection Agency (USEPA). This section presents an explanation of these programs. Results of these programs provide the NADP Program Office, funding agencies, and site personnel with information on whether siting criteria and equipment specifications are met, standard operational procedures are followed, and NTN bias and precision goals are achieved. Both agencies issue reports of their findings. Copies are available from the NADP Program Office (see Section 7.2 for contact information). In addition, results of these programs are reported at twice yearly NADP Subcommittee meetings.

6.1 NTN Site Systems and Performance Survey

In this quality assurance program, trained inspectors from ATS, Inc., under USEPA contract, conduct a systems and performance survey of each NTN site approximately every two years. The goals of this survey are to check for siting and equipment problems, ensure that standard NTN procedures are followed, and provide Site Operators with technical assistance in making adjustments in equipment or in correcting procedures.

During the survey the inspectors visit the field site where they make observations and perform various measurements of the ACM collector and Belfort gage. Both pieces of field equipment are tested to ensure they operate within network specifications. If specifications are not met, the inspectors may help the Site Operator to make necessary adjustments or recommend actions to correct the problem. The inspectors prepare a site sketch and record the location and orientation of NTN and other equipment, as well as the location, distance, and height of trees, bushes, or other obstructions that may interfere with sampling. The inspectors also take a set of photographs of the NTN equipment and site, and make notes about the surroundings. Of particular interest is the ground cover within 30 meters of the equipment and the location of roads, residences, storage structures, agricultural facilities, and other nearby sources of air pollutants that may affect the chemistry of wet deposition at the site. The inspectors record the distance from the field equipment to these sources, noting any deficiencies according to the criteria specified in the *NADP/NTN Instruction Manual: Site Selection and Installation* (NADP, 1984). As described in Section 2.2, these criteria are designed to ensure that NTN sites avoid unrepresentative influences from nearby sources.

The inspectors evaluate the performance of the Site Operators, who use their field laboratory equipment to measure a test solution. When equipment problems or deficient laboratory procedures are discovered, the inspectors offer advice on ways to improve procedures or correct problems. Other areas of performance reviewed by the inspectors include: collecting, handling, and measuring wet deposition samples; servicing the Belfort gage; recording data; and maintaining site documentation and data records. The goal is to ensure that standard NTN procedures are followed and offer improvements that can correct faulty procedures or equipment and prevent the loss of information or samples.

During every step of the survey, Site Operators are encouraged to ask questions and seek advice and assistance. These visits are intended to offer an opportunity for program representatives to visit with site personnel, answer questions, help with problems, and listen to concerns. Site Operators and

Supervisors are notified approximately a month in advance of planned visits. The visits occur during a mutually agreed upon time when both the Site Operator and Supervisor can meet with the inspectors. A site survey usually requires 4-5 hours. At the conclusion of the survey, a brief report is delivered to the Site Operator and Supervisor, and a complete report is sent to the NADP Program Office and CAL. Results of the site surveys are summarized in contract reports, which are available from the NADP Program Office (see Section 7.2 for contact information).

6.2 Blind-Audit Program

The blind-audit program is designed to assess the possible biases in NTN measurements resulting from the sample containers and from routine sample handling, shipping, and field measurements. Site Operators are required to submit a blind-audit sample approximately every 2 years. This program is called the blind-audit program because the sample identity is intentionally withheld from the CAL staff. Among the samples submitted each week, the CAL staff are not informed which ones are blind-audit samples, nor their chemical composition. These samples are synthetic solutions with a composition that simulates precipitation. The terminology quality assurance officers use to describe a sample that has an unknown identity *and* an unknown composition is “double blind.” Blind-audit samples are a double-blind quality assurance audit of NTN measurements. The blind-audit program is administered by the USGS Branch of Quality Systems, and the USGS project officer identifies these samples only after the CAL analyses have been completed. Then the blind-audit samples are coded as quality assurance samples to prevent them from being confused with wet deposition samples.

The USGS project officer sets a schedule that specifies the sites and dates for submission of blind-audit samples. Samples are sent to the sites well before the scheduled date of submission. Each sample is accompanied by a detailed set of instructions that states when to send the sample, how to label it, how to handle it, and what information to record on the FORF that the Site Operator submits to the CAL with the sample. Information recorded on the FORF disguises the sample by making it appear to be a wet deposition sample from the site. To prevent any lapses in a site’s wet deposition record, the Site Operator collects a real sample for the sampling period when the blind-audit sample is submitted. The identity of the real sample is disguised, but the sample is collected and sent to the CAL following standard procedures. Once the CAL is informed of the true identity of the blind-audit and real samples, the records and database are updated to reflect the actual data.

Site Operators receive the blind-audit sample in a clearly labeled bottle. Instructions accompanying the sample tell the Site Operator to pour ~75 percent of the blind-audit sample into a clean bucket, cover the bucket with a clean lid, and let it stand for ~24 hours. From this point, this portion of the sample is handled, measured, and shipped as if it were a wet deposition sample. The only departure from standard procedures is that the instructions specify what precipitation amounts to record on the FORF so that the precipitation data are consistent with the sample volume. Otherwise, a mismatch in the sample volume and precipitation amount may signal the CAL that this is a blind-audit sample. The portion of the blind-audit sample remaining in the original bottle is sent to the CAL separately for analysis. Analysis results from this portion of the sample are compared with those for the portion sent as a wet deposition sample. Differences indicate possible biases in NTN measurements from the sample containers and from routine sample handling, shipping, and field measurements.

Site Operators are contacted by telephone approximately a week before they are to submit the blind-audit samples to verify that they have received the samples and instructions, and to discuss any problems or questions they may have concerning the submission. Results from this program are reported in USGS reports (Gordon et al., 1997) and are available from the NADP Program Office (see Section 7.2 for contact information).

6.3 Intersite Comparison Program

Twice a year Site Operators are asked to measure the pH and conductivity of an intersite comparison sample supplied by the USGS Branch of Quality Systems. These samples are synthetic solutions that simulate precipitation. Different formulations are used for each set of tests. Site Operators are not told the target concentrations of the solutions. In other words, the intersite comparison samples are “single blind” to the Operators because they know they are being tested but not the expected results. Specific instructions for measuring the intersite comparison samples are sent with each sample. Site Operators report their measurements to the USGS Project Officer, who uses the results to assess the bias and precision of Site Operator pH and conductivity measurements.

A statistical summary of all of the measurements is reported to participating Site Operators, along with a graphical presentation of the target pH and conductivity values and acceptable ranges of measurements. Operators can see whether their measurements were acceptable, i.e., met the accuracy goals. Operators who do not meet the goals are asked to participate in a follow-up study conducted by the USGS. The purpose of the follow-up study is to resolve the cause of the measurement difficulties. They can also contact the CAL for assistance (see Section 7.1 for contact information) or consult Appendix B. Results from this program are reported in USGS reports (Gordon et al., 1997) and are available from the NADP Program Office (see Section 7.2 for contact information).

6.4 Collocated Sampler Program

The USGS Branch of Quality Systems sponsors this program to determine the overall precision of measuring precipitation amounts and chemistry, including the variability from sample collection through data validation and storage (See et al., 1990). Precision is calculated by comparing data for paired, collocated ACM collectors and Belfort gages operated at a site for 1 year. These paired instruments are the original site equipment and a second (collocated) set installed and operated according to standard procedures. Site Operators collect two samples and change two raingage charts each week. At the field laboratory, they handle and measure the samples independently, record data and observations on separate FORFs, and send both samples to the CAL. CAL technicians treat and analyze the samples as if from separate sites and screen, verify, and store the data independently in the database. After 1 year of collocated sampler operation, the second set of equipment moves to another site. Collocated sampling is performed at two or more sites each year.

The USGS Project Officer chooses sites where collocated sampling will occur after consulting and reaching agreement with site personnel. Three criteria govern site selection (See et al., 1990): (1) distribution among diverse regions; (2) distribution among low, medium, and high rainfall regions; and (3) site operational history. Once a site agrees to participate, the USGS ships the collocated field equipment to the site and is responsible for its proper installation. A schedule is set for starting the collocated sampling. When sampling ends, the USGS is responsible for equipment removal.

Differences in weekly chemical and precipitation measurements are calculated for valid collocated samples, and these differences are used to determine precision estimates for each chemical and for precipitation amounts. Results are reported in USGS reports (Gordon et al., 1997) and are available from the NADP Program Office (see Section 7.2 for contact information).

6.5 Field Blank Program

This program attempts to quantify biases from contamination that enters the wet-side bucket installed in the ACM collector for an entire sampling period plus contamination from routine sample handling, shipping, and field measurements. The possible contamination entering the bucket while it is installed in the ACM collector is a major difference between this program and the blind-audit program described in Section 6.2. Another difference is that there is no effort to disguise field blank samples from the CAL. Although the lid seal of the ACM collector is designed to protect the wet-side sample from dry deposition, dust can bypass this seal. Under windy and dusty conditions, this can be an important source of bias in NTN measurements. Contamination also can occur when the sample is handled and measured in the field laboratory and shipped to the CAL. By capturing all of these sources of contamination, field blank measurements include virtually all of the important sources of bias in NTN measurements caused by the equipment, containers, field procedures, and shipping.

To measure contamination from these sources, Site Operators add a synthetic solution to the wet-side bucket at the end of a sampling period when no precipitation occurred. This solution is provided by the USGS Branch of Quality Systems, which administers the program. The bucket is covered with a clean lid and left undisturbed for 24 hours. This waiting period allows the solution to remain in contact with the inside walls of the bucket, simulating the contact a rain sample has with the bucket surface. The Operator then handles the solution as a wet deposition sample, weighing it, transferring it to a sample bottle, measuring the pH and conductivity on a portion of the sample, and sending it to the CAL, along with a portion of the original solution. Analyses of this solution and the original solution are compared. Differences in these measurements are used to quantify the accumulated effects of these contamination sources. This program was initiated in October 1996. Results will be reported in future USGS reports.

6.6 References

Gordon, J., M. Nilles, D. Polacsek, and M. Ratcliff. 1997. *External Quality-Assurance Results for the National Atmospheric Deposition Program/National Trends Network during 1994*. U.S. Geological Survey, Water Resources Investigations Report 97-4201, Denver, CO.

NADP, 1984. *NADP/NTN Instruction Manual: Site Selection and Installation*. NADP Program Office, Champaign, IL.

See, R., T. Willoughby, M. Brooks, and J. Gordon. 1990. *Programs and Analytical Methods for the U.S. Geological Survey Acid Rain Quality-Assurance Project*. U.S. Geological Survey, Water Resources Investigations Report 90-4029, Denver, CO.

7 Directory

7.1 NADP - Central Analytical Laboratory

Illinois State Water Survey
2204 Griffith Drive
Champaign, IL 61820-7495

Web Address: <http://nadp.sws.uiuc.edu/cal>
E-mail for site support: ntn@sws.uiuc.edu
E-mail for general information: cal@sws.uiuc.edu

For Questions About	Contact
<p>Site Equipment ...problems, troubleshooting, winter operations ...requirements, calibrations, tests</p> <p>Site Operations ...standard procedures ...training video/CDROM, <i>Site Operation Manual</i> ...annual field operations training course</p> <p>Monthly Site Preliminary Data Reports ...explanations, error messages, notes</p> <p>Shipping and Site Supplies ...requirements, problems ...shipping vendors ...supplies not listed on field forms</p>	<p>Matt Layden, Site Liaison Phone: 1-800-952-7353 Fax: 217-333-0249 E-mail: ntn@sws.uiuc.edu</p>
<p>Central Analytical Laboratory Operations ...general information about the CAL ...administrative issues ...sample handling procedures, laboratory operations ...analytical methods, material safety data sheets (MSDS)</p>	<p>Karen Harlin, CAL Director Phone: 217-244-6413 Fax: 217-244-3054 E-Mail: kharlin@uiuc.edu</p>
<p>CAL Office ...contact other staff ...training course registration</p>	<p>Pam Bedient, Administrative Assistant Phone: 217-244-0868 Fax: 217-244-3054 E-Mail: cal@sws.uiuc.edu</p>
<p>Quality Assurance ...Central Analytical Laboratory QA/QC</p>	<p>Jane Rothert, CAL QA Specialist Phone: 217-333-7942 Fax: 217-244-3054 E-mail: rothert@uiuc.edu</p>

7.2 NADP Program Office

Illinois State Water Survey
2204 Griffith Drive
Champaign, IL 61820-7459

Web Address: <http://nadp.sws.uiuc.edu>
E-mail: nadp@sws.uiuc.edu

For Questions About	Contact
<p>NADP ...general information about the program</p> <p>National Trends Network (NTN) and Atmospheric Integrated Research Monitoring Network (AIRMoN) ...general information ...requirements, costs, contracts</p>	<p>Van Bowersox, NADP Coordinator Phone: 217-333-7873 Fax: 217-333-0249 E-mail: sox@sws.uiuc.edu</p>
<p>Mercury Deposition Network (MDN) ...general information ...requirements, costs</p>	<p>David Gay, Asst. Coordinator for Toxics Phone: 217-244-0462 Fax: 217-333-0249 E-mail: dgay@uiuc.edu</p>
<p>Selecting and Installing a Site ...how to install the NADP precipitation collector ...how to install the recording raingage ...power requirements, rules, equipment spacing ...application to enter network</p>	<p>Roger Claybrooke Phone: 217-244-2838 Fax: 217-333-1708 E-mail: dclay@sws.uiuc.edu</p>
<p>Database/Web Page ...color maps, tables, figures ...special data requests</p>	<p>Bob Larson Phone: 217-333-9008 Fax: 217-333-1708 E-mail: blarson@sws.uiuc.edu</p>
<p>Meetings and Publications ...annual Technical Committee meeting ...subcommittee meetings ...meeting proceedings, reports, brochures</p>	<p>Kathy Douglas Phone: 217-333-7871 Fax: 217-333-0249 E-mail: kathy@sws.uiuc.edu</p>
<p>Quality Assurance ...QA/QC procedures ...bias, precision, blank levels ...network comparisons</p>	<p>Chris Lehmann Phone: 217-265-8512 Fax: 217-333-0249 E-mail: clehmann@uiuc.edu</p>
<p>Sample Archives ...inquiries, procedures, and requests for NTN and AIRMoN samples</p>	<p>Karen Harlin, Assistant Coordinator Phone: 217-244-6413 Fax: 217-244-3054 E-mail: kharlin@uiuc.edu</p>

7.3 External Quality Assurance Programs

For Questions About	Contact
<p>USGS External Quality Assurance Project</p> <p>Data and Program Related Issues ...QA project planning ...data analysis and reports</p> <p>Field Logistics Mercury Deposition Network (MDN) ...system blank program ...blind audit program ...interlaboratory comparison program</p> <p>National Trends Network (NTN) ...collocated sampler program ...field blank/audit program ...interlaboratory comparison program</p>	<p>Gregory Wetherbee, Project Chief, Chemist USGS Water Resources Discipline, Branch of Quality Systems (USGS, WRD, BQS) Box 25046, MS 401, Bldg. 95 Denver Federal Center Denver, Colorado 80225</p> <p>Phone: 303-236-1837 Fax: 303-236-1880 E-mail: wetherbe@usgs.gov http://bqs.usgs.gov/precip/new/frontpage_home.htm</p> <hr/> <p>Natalie E. Latysh, Hydrologist USGS Water Resources Discipline, Branch of Quality Systems (USGS, WRD, BQS) Box 25046, MS 401, Bldg. 95 Denver Federal Center Denver, CO 80225</p> <p>Phone: 303-236-1874 Fax: 303-236-1880 E-mail: nlatysh@usgs.gov http://bqs.usgs.gov/precip/new/frontpage_home.htm</p>
<p>USEPA Site Systems and Performance Surveys ...program objectives ...on-site reviews and inspections ...site representativeness</p>	<p>Michael J. Kolian U.S. Environmental Protection Agency Office of Air Programs (OAP) Clean Air Markets Division (6204J) 1200 Pennsylvania Avenue, NW Washington, DC 20460</p> <p>Phone: 202-343-9261 Fax: 202-343-2360 E-mail: kolian.michael@epa.gov</p>

7.4 Instrument Manufacturers

For Questions About	Contact
<p>Wet Deposition Collector ...purchases ...optional features</p> <p>Event Recorder ...single pen ...dual pen</p>	<p>Aerochem Metrics, Inc. 4473 West Highway 476 Bushnell, Florida 33513</p> <p>Phone: 352-793-8000 Fax: 352-793-3954</p> <hr/> <p>LODA Electronics Co. 307 South Elm P.O. Box 207 Loda, IL 60948-0207</p> <p>Phone: 217-386-2554 Fax: 217-386-2439 E-mail: loelco@prairieinet.net http://www.lodaelectronics.com</p>
<p>Recording Raingage ...purchases</p>	<p>Van Bowersox, NADP Coordinator Phone: 217-333-7873 E-mail: sox@sws.uiuc.edu</p>

Appendix A National Trends Network (NTN) Equipment Requirements

A.1 Field Site Equipment

Precipitation Collector: Two wet deposition collectors meet current NADP specifications: the Aerochem Metrics model 301 and the LODA model 2001 (see Sections 2.3 and 3.1). Section 7.4 lists contact information for the manufacturers.

Recording Raingage Equipped with Event Recorder: The Belfort model B5-780 recording raingage is the only raingage that meets NTN requirements (see Sections 2.3 and 3.1). This model is available only from the Belfort Instrument Company, while the NADP event recorder is available from either of the approved collector manufacturers listed in Section 7.4.

A.2 Field Laboratory Equipment

Equipment listed in this section meets NTN requirements. Examples may vary considerably in cost, serviceability, and expertise required for proper use. The NADP does not endorse any brand name.

Balance

Requirements

15 kg capacity, 1 g sensitivity/readability

Examples

Mettler model SB-16000 (top-loading electronic)

Ohaus model CHAMP CQ25R31 (top-loading electronic)

Ohaus model 1119-D0 (open beam mechanical)

pH Meter and Electrode

Meter Requirements

Read 0-14 pH units, digital display with readability to 0.01 pH units, microprocessor controlled with buffer recognition and auto-read capability

Meter Examples

Beckman model F250

Oakton model pH 510

Cole Parmer model A-59330-00

Orion model 250A or 410A

Corning model 430

VWR model SB20 Symphony

Fisher model Accumet AB15

Electrode Requirements : The CAL supplies a Broadley-James Combination pH Electrode model E1439-EC2-AO3. Sites are discouraged from providing their own electrode.

Specific Conductance Meter and Cell

Many conductance meters and cells have proprietary cabling. Make certain that the meter or cell you order will connect to your existing equipment, or purchase the meter and cell together.

Meter Requirements

0.1-1,000 $\mu\text{S}/\text{cm}$ range and readability to 0.1m $\mu\text{S}/\text{cm}$

Meter Examples

Cole Parmer catalog number EW-19050-00

Oakton model CON 500

VWR model 2052

VWR catalog number 23226-501 (use only with VWR catalog number 23226-524 conductance cell)

Cell Requirements

Cell constant of 1.0 and a sample volume requirement < 10 mL

Cell Examples

VWR catalog number 23226-524 or 23198-020

YSI model 3403 or 3417

Suggested Labware

500 mL squeeze bottle

disposable laboratory wipes or lint free tissues

distilled or reagent water with conductivity below 5 $\mu\text{S}/\text{cm}$

electrode holder or ring stand

small flat bottomed dishpan

Note: The CAL provides other laboratory supplies, as well as a training video or CD-ROM. Contact the CAL at 1-800-952-7353 for additional information.

A.3 NADP National Trends Network Field Chemistry Site Supplies (revised 12/3/2004)**Insert this page in the *NTN Site Operation Manual* (July 1999 edition) after page A-2.**

Description	Vendor Name	Vendor Item #	#/pkg	Approx. Price per pkg (see Note)
pH Electrode, Broadley-James	Broadley-James Corp. ¹	E-1439-EC2-AO3BC	1	\$180.00
Electrode fill solution, KCl	Broadley-James Corp. ¹	AS-3120-C20-0250	1	\$20.00
Electrode BJC-US Std Connector/adaptor	Bill Wolcott & Associates ²	AD-2000-BJ/A04SC	1	\$35.00
pH 4.0 Buffer solution	Fisher Scientific ³	23-356-113	1	\$10.00
pH 7.0 Buffer solution	Fisher Scientific ³	23-356-121	1	\$10.00
Vials, 4 mL	Fisher Scientific ³	02-544-4	1000	\$35.00
75 µS/cm Standard	Prepared by CAL Contact CAL for Standard Operating Procedure (email: CAL@sws.uiuc.edu)			
Check Sample, 4.9 pH	Prepared by CAL Contact CAL for Standard Operating Procedure (email: CAL@sws.uiuc.edu)			

¹ Broadley James Corporation, 19 Thomas, Irvine, CA 92618, 1-800-288-2833² Bill Wolcott & Associates, 3860 Candyland Lane, Morris, IL 60450, 1-800-747-7623³ Fisher Scientific, 4500 Turnberry Drive, Hanover Park, IL 60103, 1-800-766-7000

Note: Prices include Univ. of Illinois or CAL negotiated vendor discounts and may not reflect the price individual sites may pay for the same item.

Specific Conductance Meter and Cell

Many conductance meters and cells have proprietary cabling. Make certain that the meter or cell you order will connect to your existing equipment, or purchase the meter and cell together.

Meter Requirements

0.1-1,000 $\mu\text{S}/\text{cm}$ range and readability to 0.1 $\mu\text{S}/\text{cm}$

Meter Examples

Cole Parmer catalog number EW-19050-00

Oakton model CON 500

VWR model 2052

VWR catalog number 23226-501 (use only with VWR catalog number 23226-524 conductance cell)

Cell Requirements

Cell constant of 1.0 and a sample volume requirement < 10 mL

Cell Examples

VWR catalog number 23226-524 or 23198-020

YSI model 3403 or 3417

Suggested Labware

500 mL squeeze bottle

disposable laboratory wipes or lint free tissues

distilled or reagent water with conductivity below $1 \mu\text{S}/\text{cm}$

electrode holder or ring stand

small flat bottomed dishpan

Note: The CAL provides other laboratory supplies, as well as a training video or CD-ROM. Contact the CAL at 1-800-952-7353 for additional information.

Appendices B, C, and D are not currently available in the online version of the National Trends Network Operators Manual. To obtain printed copies of any of these appendices, please contact:

Pam Bedient
Illinois State Water Survey
2204 Griffith Drive
Champaign, IL 61820-7495
(217) 244-0868
pbedient@sws.uiuc.edu

